

Measurement Guide

Agilent Technologies ESA-E Series Spectrum Analyzers GSM Measurement Personality

This manual provides documentation for the following instruments:

ESA-E Series

E4402B (9 kHz - 3.0 GHz)

E4404B (9 kHz - 6.7 GHz)

E4405B (9 kHz - 13.2 GHz)

E4407B (9 kHz - 26.5 GHz)



Agilent Technologies

Manufacturing Part Number: E4401-90140

Printed in USA

March 2000

© Copyright 2000 Agilent Technologies, Inc.

Notice

The information contained in this document is subject to change without notice.

Agilent Technologies makes no warranty of any kind with regard to this material, including but not limited to, the implied warranties of merchantability and fitness for a particular purpose. Agilent Technologies shall not be liable for errors contained herein or for incidental or consequential damages in connection with the furnishing, performance, or use of this material.

Warranty

This Agilent Technologies instrument product is warranted against defects in material and workmanship for a period of three years from date of shipment. During the warranty period, Agilent Technologies Company will, at its option, either repair or replace products that prove to be defective.

For warranty service or repair, this product must be returned to a service facility designated by Agilent Technologies. Buyer shall prepay shipping charges to Agilent Technologies and Agilent Technologies shall pay shipping charges to return the product to Buyer. However, Buyer shall pay all shipping charges, duties, and taxes for products returned to Agilent Technologies from another country.

Agilent Technologies warrants that its software and firmware designated by Agilent Technologies for use with an instrument will execute its programming instructions when properly installed on that instrument. Agilent Technologies does not warrant that the operation of the instrument, or software, or firmware will be uninterrupted or error-free.

LIMITATION OF WARRANTY

The foregoing warranty shall not apply to defects resulting from improper or inadequate maintenance by Buyer, Buyer-supplied software or interfacing, unauthorized modification or misuse, operation outside of the environmental specifications for the product, or improper site preparation or maintenance.

NO OTHER WARRANTY IS EXPRESSED OR IMPLIED. AGILENT TECHNOLOGIES SPECIFICALLY DISCLAIMS THE IMPLIED WARRANTIES OF MERCHANTABILITY AND FITNESS FOR A PARTICULAR PURPOSE.

EXCLUSIVE REMEDIES

THE REMEDIES PROVIDED HEREIN ARE BUYER'S SOLE AND EXCLUSIVE REMEDIES. AGILENT TECHNOLOGIES SHALL NOT BE LIABLE FOR ANY DIRECT, INDIRECT, SPECIAL, INCIDENTAL, OR CONSEQUENTIAL DAMAGES, WHETHER BASED ON CONTRACT, TORT, OR ANY OTHER LEGAL THEORY.

Safety Information

The following safety notes are used throughout this manual. Familiarize yourself with these notes before operating this instrument.

WARNING **Warning denotes a hazard. It calls attention to a procedure which, if not correctly performed or adhered to, could result in injury or loss of life. Do not proceed beyond a warning note until the indicated conditions are fully understood and met.**

CAUTION Caution denotes a hazard. It calls attention to a procedure that, if not correctly performed or adhered to, could result in damage to or destruction of the instrument. Do not proceed beyond a caution sign until the indicated conditions are fully understood and met.

WARNING **This is a Safety Class 1 Product (provided with a protective earth ground incorporated in the power cord). The mains plug shall be inserted only in a socket outlet provided with a protected earth contact. Any interruption of the protective conductor inside or outside of the product is likely to make the product dangerous. Intentional interruption is prohibited.**

WARNING **No operator serviceable parts inside. Refer servicing to qualified personnel. To prevent electrical shock do not remove covers.**

CAUTION Always use the three-prong AC power cord supplied with this product. Failure to ensure adequate grounding may cause product damage.

Contents

1. GSM Use Model	
Cellular Communications—Overview	1-2
The Fault Finding Process	1-3
Identifying Interfering Signals	1-6
Examples of Interference Signals	1-8
2. Preparing to Make GSM Measurements	
GSM Measurements	2-2
Basic Key Use	2-3
Preparing to Make Measurements	2-4
Initial settings	2-4
How to make a measurement	2-4
How to Save Measurement Results	2-6
3. Making GSM Base Station Measurements	
Chapter Contents	3-2
Making the Output RF Spectrum (ORFS) Measurement	3-3
Purpose	3-3
Measurement Method	3-3
Making the Measurement	3-5
Results	3-6
Troubleshooting Hints	3-10
Making the Phase and Frequency Error Measurement	3-11
Purpose	3-11
Measurement Method	3-11
Making the Measurement	3-11
Results	3-12
Troubleshooting Hints	3-12
Making the Power Vs Time Measurement	3-13
Purpose	3-13
Measurement Method	3-13
Making the Measurement	3-14
Power vs Time Custom Masks	3-14
Results	3-15
Changing the View	3-16
Changing the Display	3-16
Troubleshooting Hints	3-16
Making The Power Steps Measurement	3-17
Purpose	3-17
Measurement Method	3-17
Making the Measurement	3-17
Results	3-18
Making the Transmitter Power Measurement	3-19
Purpose	3-19
Measurement Method	3-19
Making the Measurement	3-20
Results	3-21
Troubleshooting Hints	3-22

4. Making GSM Air Interface Measurements

Chapter Contents	4-12
Making the Monitor Band/Channel Measurement	4-13
Purpose	4-13
Measurement Method	4-13
Making the Measurement	4-13
Results	4-14
Troubleshooting Hints	4-15
Making the Out-of-Band Spurious (OOBS) Measurement	4-16
Purpose	4-16
Measurement Method	4-16
Making the Measurement	4-16
Results	4-17
Inspecting Results	4-17
Troubleshooting Hints	4-18
Making The Transmitter Receive (Rx) Band Spurious Measurement	4-19
Purpose	4-19
Measurement Method	4-19
Making the Measurement	4-110
Results	4-111
Inspecting Results	4-112
Troubleshooting Hints	4-112
Making the Transmitter Transmit (Tx) Band Spurious Measurement	4-113
Purpose	4-113
Measurement Method	4-113
Making the Measurement	4-113
Results	4-114
Inspecting Results	4-115
Troubleshooting Hints	4-115
Making the Transmitter Power Measurement	4-116

5. Making GSM Cable and Antenna Measurements

Chapter Contents	5-2
Making cable fault location measurements	5-3
Purpose	5-3
Making return loss measurements	5-8
Purpose	5-8
Making the measurement	5-8
Example	5-9
Making loss/gain measurements	5-14
Purpose	5-14
Making the measurement	5-14
Example	5-15

1 GSM Use Model

Cellular Communications—Overview

Figure 1-1 Cellular Site Components

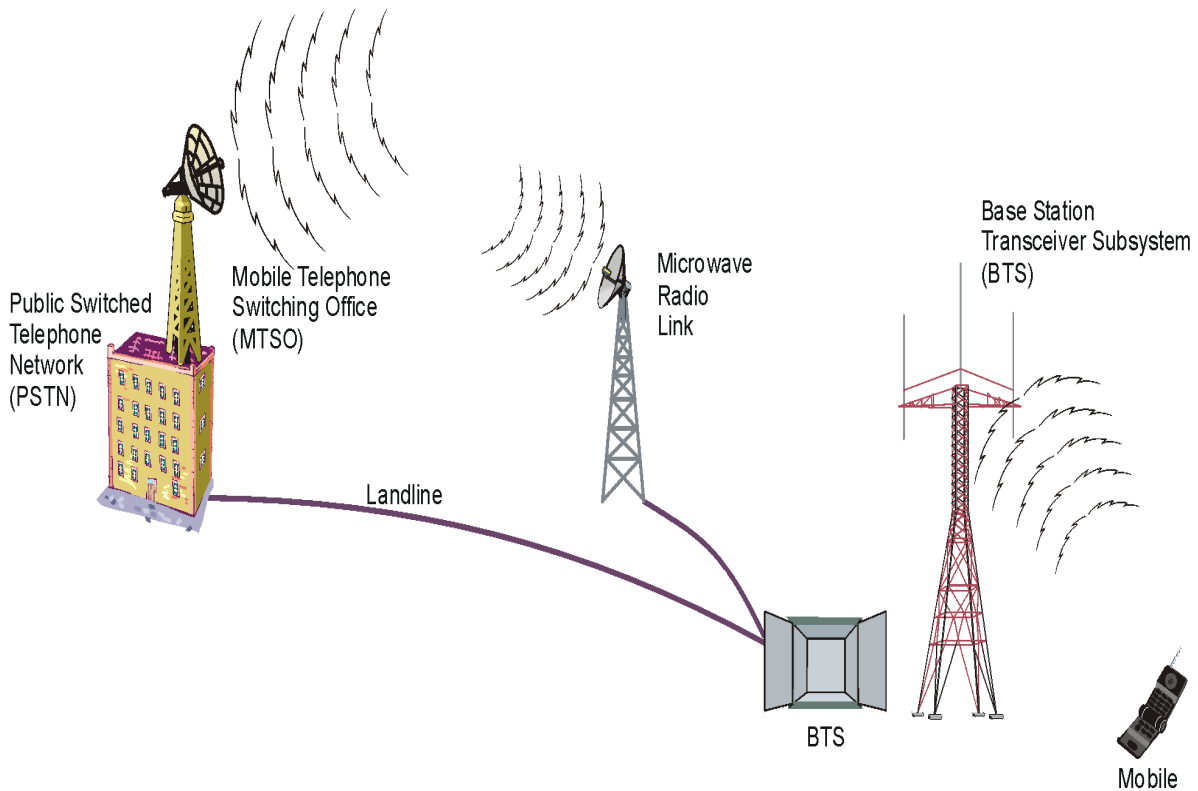

bl78b

Wireless Digital communications systems are made up of five parts: a central phone switching system, a microwave or landline link, a base transceiver station (BTS), an antenna and preamplifier system, and the air interface with the mobile device. The ESA is designed to verify the satisfactory operation of the base station system which includes the microwave link, the base transceiver station, the antenna and preamplifier system, and the air interface with the mobile device. The measurements in this guide are divided into chapters according to the subsystems that each tests.

The Fault Finding Process

Four key elements, shown in [Figure 1-2](#), can contribute to degraded cell performance:

- The **transmitter** is often described as the hardest working component of the cell site. Linear power amplifiers generate high power radio signals and run at high temperatures. Insufficient heat dissipation in humid climates can cause the transmitters to overheat, or extremes of cold can cause transmitter heat sinks to crack. As a result, specified performance will be degraded, causing low power transmissions, impaired modulation, and poor adjacent channel performance.
- **Cables and antennae** are directly exposed to the elements. Weather-damaged antennas, cables, and the connectors can further degrade performance. Sometimes a low noise amplifier close to the antenna is used to boost the signal or microwave radio transceivers are used to link the cell site to the communications network. These components are just as exposed to the same harsh environmental conditions making them prone to failure.
- When a mobile site transmits, other radio systems can interfere with the propagated signal resulting in a degraded signal at the cell site receiver. On the journey, **interference** from other radio systems can degrade the signal. Tall buildings and hills can deflect the signal away from the antenna and signal degradation can result.

Figure 1-2 Sources Of System Degradation

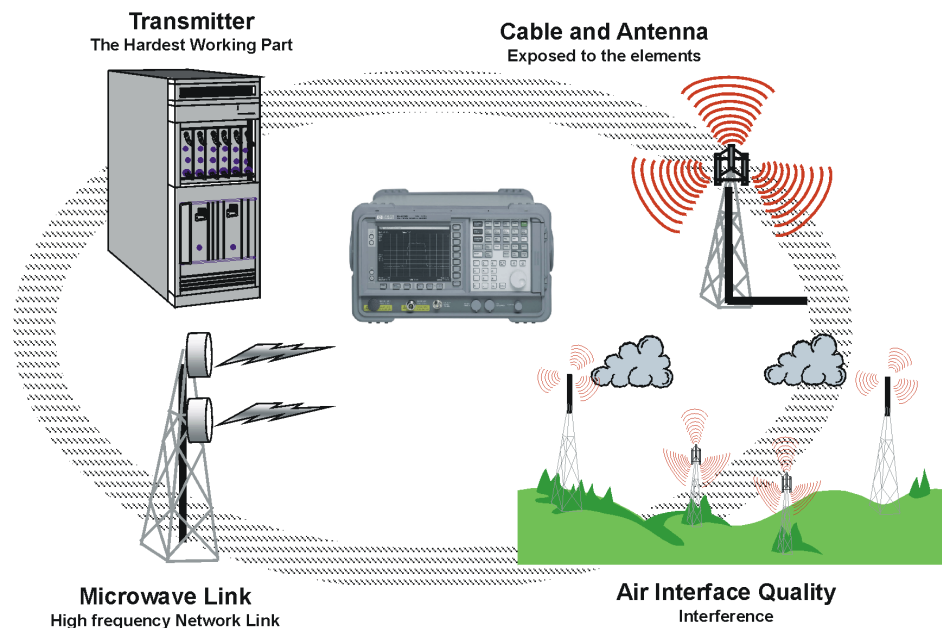

bl716b

To help identify which component of the cell site is contributing to performance problems, a fault finding process is needed. Essentially, once the radio signal is modulated and transmitted, it is prone to degradation. The once perfect, error corrected, monitored digital signal, now has all the characteristics of any analog radio signal. What you want to do is ensure its transmission path is clear and presents no barriers that will hinder its performance. Starting at the transmitter, as indicated in Figure 1-3, you need to check that the correct signal is being generated.

You then need to ensure that it passes through the various cables and connectors without degrading its quality. Once transmitted through the antenna, a clear interference free radio band is required to ensure the handset receives the signal correctly. Then in reverse, you need to verify the reception band is clear and the path from the antenna to the receiver presents no obstacles to the radio receiver equipment, which will decode the signal and convert it back into digital data.

When troubleshooting, you need to ask ourselves a set of basic questions. The first thing to question is the transmitter operation where the signal originates. If this is operating satisfactorily, then you need to determine that intermediate components are not attenuating the signal. Finally, you need to ensure that maximum power is being transferred into the antenna feed and array. On the receive side, you again need to ensure that maximum power is being transferred from the antenna to the BTS. You also need to ensure that intermediate components do not over-attenuate the received signal.

Figure 1-3 Fault Finding Process

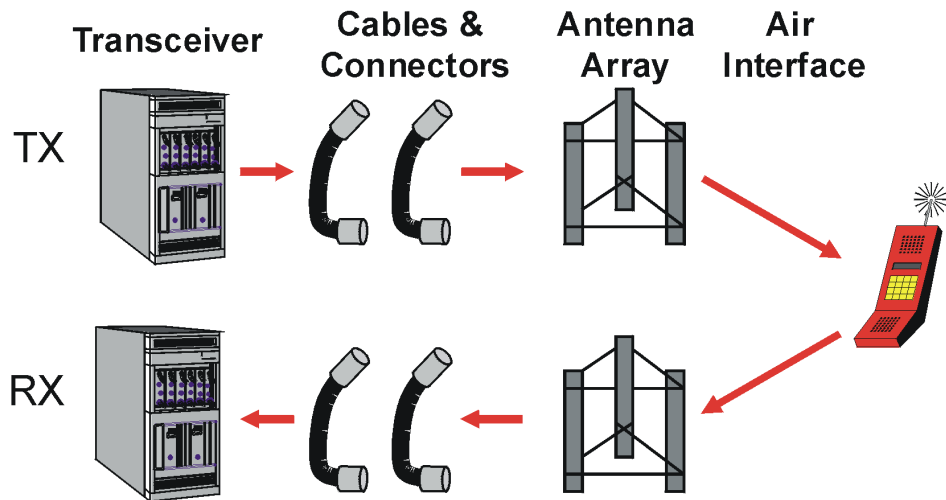

b1717b

Use [Table 1-1](#) to help determine which measurement to perform when troubleshooting your cell site base transceiver system.

Table 1-1 Troubleshooting Your Cell Site Base Transceiver System

System Component	Fault Symptom	Related Measurements	Analyzer Mode
BTS	Power Levels	Transmitter power Power vs time	GSM
	Modulation Quality	Phase and frequency error	
	Interference with other systems	Output RF spectrum (ORFS) Power Steps	
Air Interface	In-channel interference	Transmitter power Monitor band/channel	GSM
	In-band interference	Monitor band/channel Transmit band spurious Receive band spurious	
	Out of band interference	Out of band spurious	
Cables and Antenna	Amplitude flatness	Loss/gain (manual measurement)	SA
	Reflection Responses	Return loss (VSWR) (manual measurement)	
	Cable defect	Cable fault location (manual measurement)	GSM

Identifying Interfering Signals

To identify interfering signals, you must first locate them in the cdmaOne frequency band. This is best done by using the Monitor Band measurement. Sensitivity should be optimized to locate and view small interfering signals.

To optimize the spectrum analyzer for best sensitivity when identifying interference signals, three main parameters need to be understood: resolution bandwidth, internal attenuation, and internal pre-amplification:

- **Resolution bandwidth:** Choose the lowest possible resolution bandwidth filter. The noise floor decreases as resolution bandwidth decreases. This is because noise is a broadband signal, and as you reduce resolution bandwidth, less noise reaches the detector. Sweep speed is inversely proportional to the square of the resolution bandwidth and increases as resolution bandwidth decreases. To optimize speed, the smallest span and largest bandwidth possible should be used that still separates the signals and allows visibility of all signals of interest. Using monitor channel reduces the span by focusing on a specific channel instead of an entire band.
- **Attenuation:** Set the internal input attenuator to the least possible amount of attenuation, normally 0 dB. However, if the input signal total power is greater than -10 dBm for 0 dB attenuation, the analyzer may generate internal distortion. To determine if the analyzer is internally generating the distorted signals seen on the display, increase the attenuation and see if the displayed signals change in amplitude. If no amplitude change is evident, the distortion is caused by the unit under test and not the analyzer.
- **Noise floor:** Turn on the internal preamplifier (Option 1DS). This will drop the noise floor and allow you to view the signals that were previously below the analyzer noise floor.

Use this procedure and the following examples of interfering signals to help you identify the source of interfering signals and achieve the best sensitivity.

Key Press Procedure			Remarks
Step	Front-Panel Key	Menu Key	
1	Measure	More	The Monitor Band function is used to identify low-level signals that may be interfering in the up- and down-link bands. The sensitivity of this measurement is improved by reducing the resolution bandwidth and removing the analyzer attenuation through Meas Setup .
2		Monitor Band/Channel	
3	Meas Setup	Method <u>B</u> and	
4		Band Setup	
5		Res BW <u>M</u> an	As the resolution bandwidth gets smaller, the sweep time gets longer.
6	↓ (Down Arrow)		
7	Input/Output	RF Input Range <u>M</u> an	
8	AMPLITUDE Y Scale	Attenuation	To achieve 0 dB attenuation, you must enter the value using the numeric key pad. This is a safe guard against inadvertent front-end overload.
9	↓ (Down Arrow)		
10	Peak Search		The marker is used to determine the frequency of the suspected interference signal.
11	FREQUENCY Channel	Channel Freq and enter the marker frequency.	
12	Meas Setup	Method <u>C</u> hannel	The spectrum shape of the suspect signal can now be seen.
13	Input/Output	Int Preamp <u>O</u> n	For very low level signals, use the built-in preamplifier to amplify the input so that the signals appear above the noise floor of the spectrum analyzer.

CAUTION

Use a simple attenuator test to determine whether displayed distortion components are true input signals or internally generated signals caused by mixer overload. Press **AMPLITUDE**, **Attenuation**, and ↑ to increase the attenuation. If the amplitude of the suspected signal changes, then it is internally generated. Continue increasing the attenuation until the displayed distortion does not change, then complete the measurement.

Examples of Interference Signals

Use these signal examples to help assess the bandwidth and spectral shape of the interfering signal to determine the type of transmission causing the interference. Best sensitivity is achieved using narrow resolution bandwidths and minimum attenuation with the built-in preamplifier Option 1DS. The resolution bandwidth used must be larger than the signal bandwidth to display the amplitude accurately. As the resolution bandwidth decreases, the amplitude of the broadband signal decreases. Use the settings in the following examples to identify the various signals.

Using Monitor Band/Channel to Look for Interfering Signals

Using Monitor Band and Channel feature can help you quickly identify interfering signals within your transmission and reception bands or channels. Simple visual inspection, peak hold, and markers can help to determine the type of interference that may be causing network problems.

Commercial AM/FM Broadcast Signal

Press **MEASURE**, **More**, **Monitor Band/Channel**, **Meas Setup**, **Method Channel**

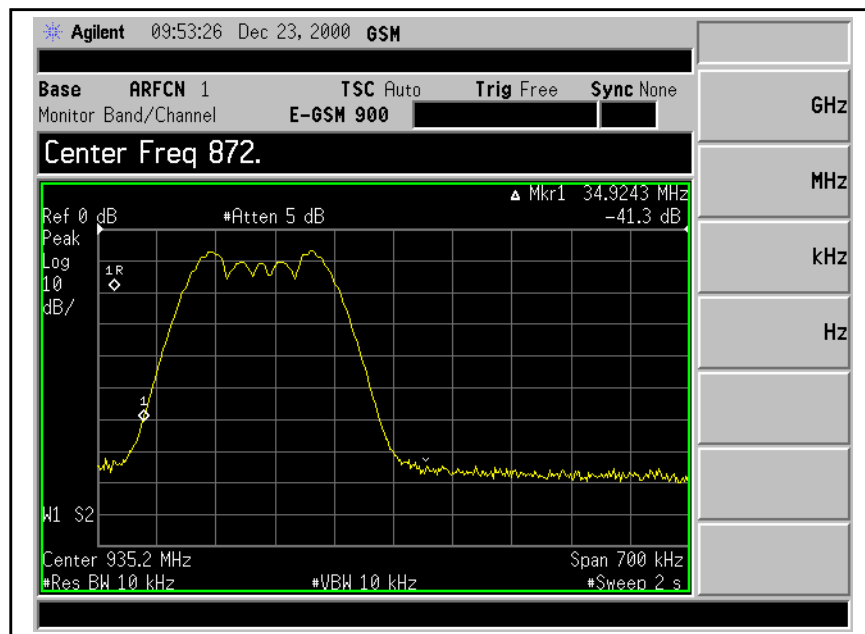

A narrow bandwidth signal within a channel could be caused by AM/FM channels. In SA mode use the built-in AM or optional FM (Option BAA) demod to determine the source of the transmission.

Commercial TV Broadcast Signal

Press **MEASURE**, More, Monitor Band/Channel, Meas Setup, Method Band

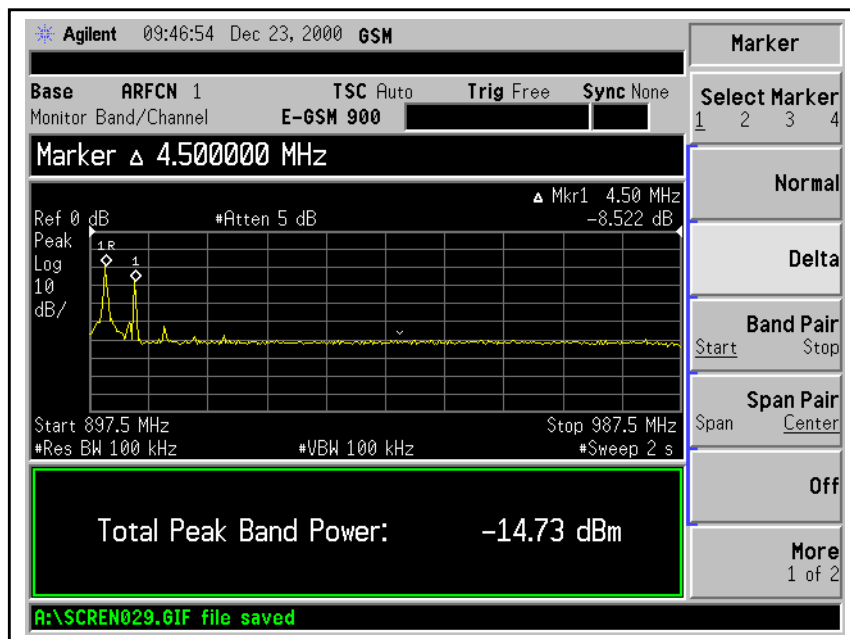

An interfering TV signal can be quickly visually verified by its unique spectral characteristics (two large carriers 4 to 6 MHz apart). In SA mode, use TV Trigger and Picture on Screen, and FM Demodulation (Options BAA and B7B) to determine the transmission source.

GSM Signals

Press **MEASURE**, **More**, **Monitor Band/Channel**, **Meas Setup**, **Method Band**

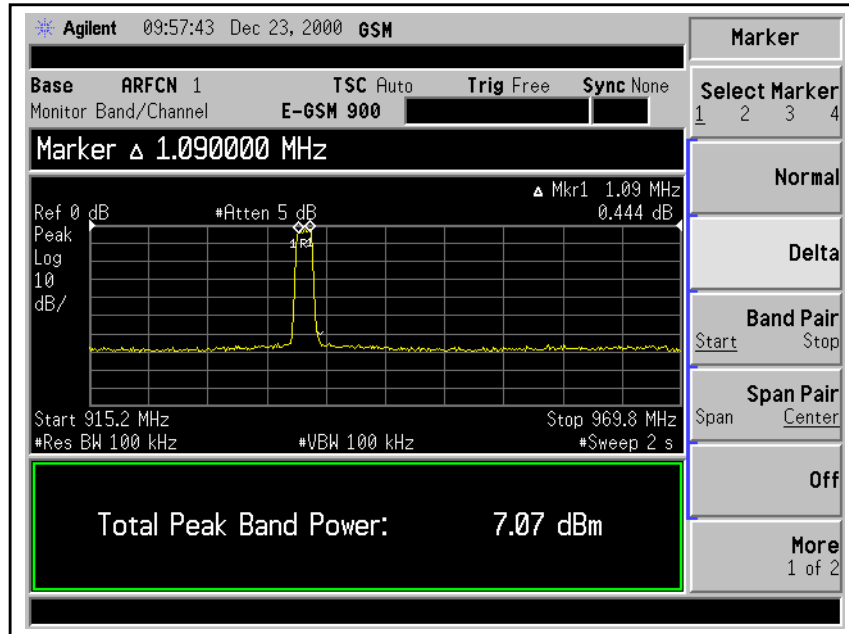

Adjacent interfering GSM signals will have this type of spectral characteristic.

GSM/PCS Signal

Press **MEASURE**, **More**, **Monitor Band/Channel**, **Meas Setup**, **Method Band**, **Chan Setup**, **Max Hold On**

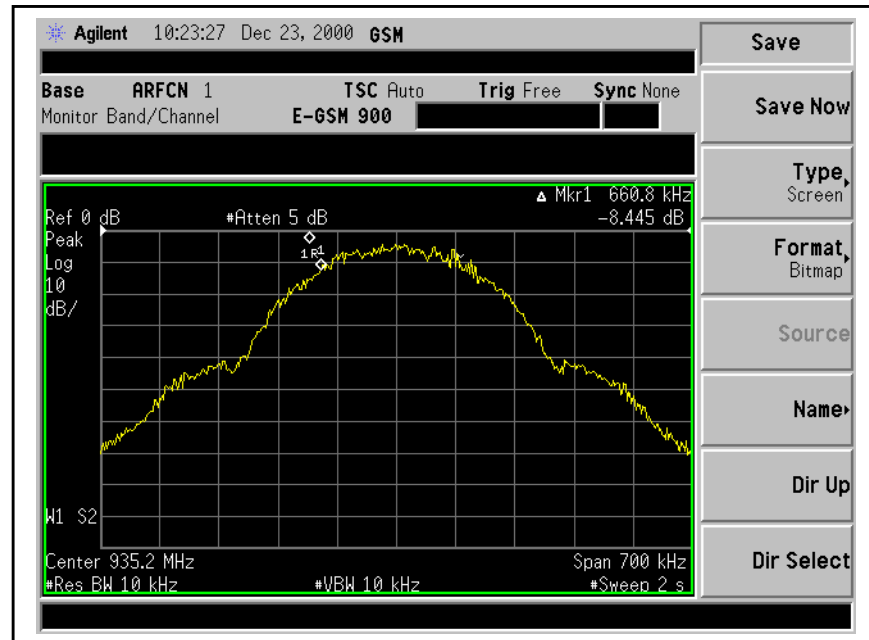

GSM/PCS networks can cause in-band interference. A GSM signal will have this type of spectral characteristic.

2

Preparing to Make GSM Measurements

This chapter introduces the basic measurement procedure including mode setup and changing measurement frequency.

GSM Measurements

The following GSM measurements are available in GSM mode and described in this document:

- Monitor band/channel on page 4-3.
- Out of band spurious on page 4-6.
- Output RF spectrum (ORFS) on page 3-3.
- Phase and frequency error on page 3-11.
- Power steps on page 3-18.
- Power vs time on 3-14.
- Receive (Rx) band spurious on page 4-9.
- Transmit (Tx) band spurious on page 4-13.
- Transmitter power on page 3-20.

These are referred to as one-button measurements. When you press the key to select the measurement it becomes the active measurement, using settings and a display unique to that measurement. Data acquisitions automatically begin provided trigger requirements, if any, are met.

In addition to the above, the following manual measurements (measurements which are not activated by a single key-press) are also described in this document:

- Cable fault location (available in SA mode) on page 5-3.
- Loss/gain (available in SA mode) on page 5-14.
- Return loss (VSWR) (available in GSM mode) on page 5-8.

Basic Key Use

The **Mode** key, allows you choose basic Spectrum Analyzer or cdmaOne functionality. Next set global measurement defaults in the analyzer based on your system using **Mode Setup**, for example, IS-95A or J-STD008. When you select a standard, the analyzer will set measurement parameters to meet the standard requirements.

The **Channel Frequency** or **RF Channel** keys allow you tune the analyzer to specific frequencies. You can do this by either setting absolute frequencies or by setting the channel number when in cdmaOne mode.

You can select a number of previously-configured standards based measurements to help you troubleshoot a system using the **Measure** button. Because all measurement situations are different, **Meas Setup** allows you to quickly change some of the measurement parameters. Finally, if you need to quickly start the measurement again, press **Restart** or use **Restart** under **Meas Control**.

Figure 2-1 Basic Keys

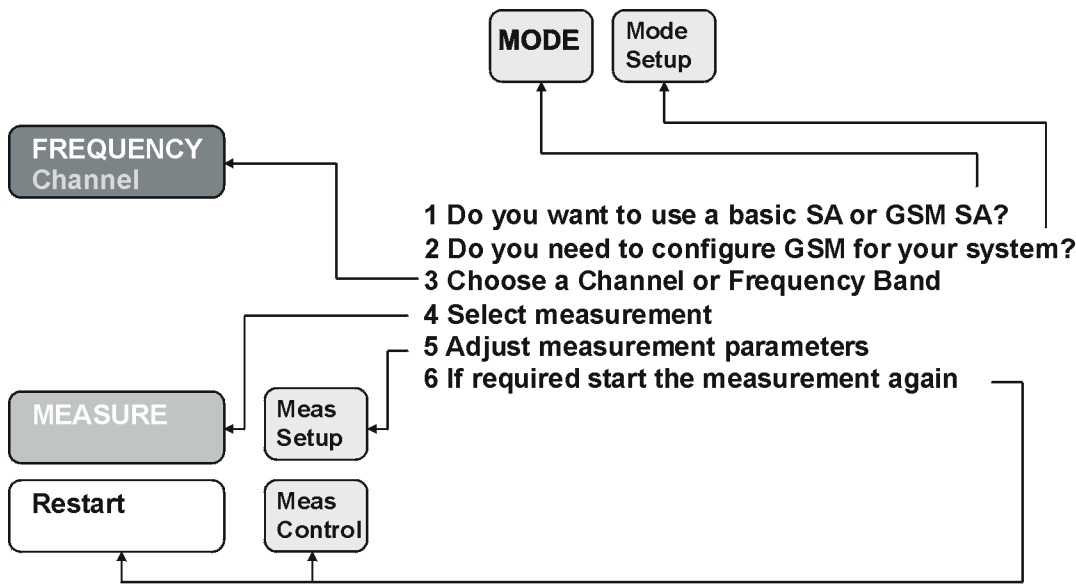

bl725b

Preparing to Make Measurements

At initial power up, the analyzer is in spectrum analyzer (SA) mode, with the Meas Off selected in the **MEASURE** menu and the **FREQUENCY Channel** menu displayed.

To access the GSM measurement personality, press the **MODE** front panel key and select the **GSM** menu key.

Initial settings

Before making a measurement, make sure the mode setup, measurement setup, and frequency channel parameters are set to the appropriate settings. For further information refer to MODE Setup, FREQUENCY/Channel and Meas Setup in Chapter 5 of the *ESA-E Series Spectrum Analyzers GSM Measurement Personality User's Guide*.

- **Resetting all parameters:**
To set all instrument parameters (including mode setup and measurement setup parameters) to factory default values, press the **Preset** front panel key. Note that the mode is changed from GSM to SA when the **Preset** front panel key is used. After using **Preset** you must use the **MODE** key to return to GSM mode.

The **Preset** front panel key can also be used to return the instrument to a set of user preset values.

- **Resetting mode setup parameters:**
Mode setup parameters apply to all measurements in GSM mode. To reset them to factory default values, press **Mode Setup** then **Restore Mode Setup Defaults**.
- **Resetting measurement setup parameters:**
Measurement setup parameters affect the current measurement only. To reset them to factory default values (for the current measurement only), press **Meas Setup** then **Restore Meas Defaults**.

How to make a measurement

Using default parameters

GSM measurements are intended to be used as “one button” measurements. This means that the appropriate measurement can be selected and run by a single key press once the instrument has been connected to the equipment to be tested. The measurement is made automatically using default parameters defined by the selected standard and the tuning plan.

Using non-default parameters

NOTE Most measurements can be performed satisfactorily using only the primary keys shown in conjunction with a minimum of set up keys. Be careful when using measurement setup (**Meas Setup**) keys as changing some measurement defaults may affect the accuracy of test results.

When it is necessary to change the default parameters, use the following four step procedure:

Step	Primary Key	Setup Keys	Related Keys
1. Select and setup mode	MODE	Mode Setup	System
2. Select and setup measurement	MEASURE	Meas Setup, Restore Meas Defaults, FREQUENCY Channel	Meas Control, Restart
3. Select and setup view	View/Trace	Span X Scale, Amplitude Y Scale, Display	Marker, Search
4. Saving and printing results	File Print	Print Setup	Save

The primary keys required for performing one button measurements are shown in the following diagram:

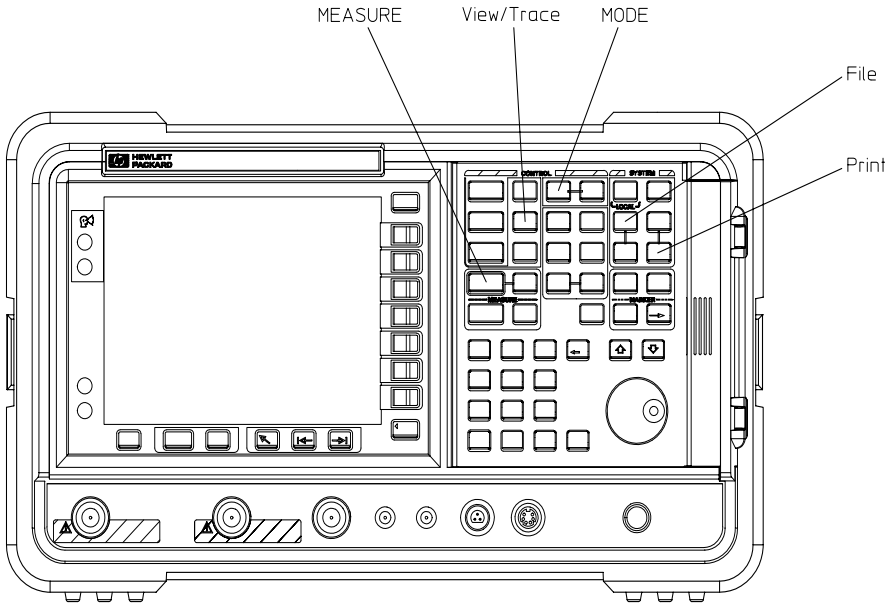

r171b

How to Save Measurement Results

To save measurement results, follow the process shown below. For additional information on file management in the spectrum analyzer, refer to the *ESA Spectrum Analyzers User's Guide*.

1. Press **File, Save, Type, More, Measurement Results**.
2. If you want to change the file name, press **Name**, and use the Alpha Editor to enter the new name. For more information on using the Alpha Editor, refer to the *ESA Spectrum Analyzers User's Guide*.
3. Press **Save Now** to complete the file saving process.
4. If you have used the default file name and wish to save additional measurement results, press **Save**. The current measurement result will be saved with the next default file name.
5. If you have not used the default file name and wish to save additional measurement results, repeat steps 1 through 3.

Chapter Contents

This chapter details how to make GSM base station measurements. The following measurements are described:

- Output RF spectrum (ORFS).
- Phase and frequency error.
- Power vs time.
- Power steps.
- Transmitter power.

Making the Output RF Spectrum (ORFS) Measurement

Purpose

The Output RF Spectrum (ORFS) measurement is GSM's version of adjacent channel power (ACP). Either a single offset is measured with the corresponding trace visible or multiple (up to 15) offsets are measured and a table is displayed. It is also possible to measure output RF spectrum as a swept measurement.

The output RF spectrum measurements determine the spectral energy emitted into the adjacent channels. Since GSM is a TDMA format, RF power is being switched on and off depending on whether the actual burst is being transmitted. The switching of power causes spectral splatter at frequencies other than that being transmitted by the carrier. Fast transitions in the time domain causes switching transients that have high frequency content associated with them.

Excessive amounts of energy spilling into an adjacent frequency channel could interfere with signals being transmitted to other MS or BTS. The measurements are divided into two main groups: spectrum due to the 0.3 GMSK modulation and noise, and spectrum due to switching transients (burst ramping).

NOTE

The default output RF spectrum measurements do not perform tests at frequency offsets greater than 1800 kHz from the carrier.

Measurement Method

In this measurement, the transmitter (source) is set to transmit a GSM frame at a given channel (frequency). The instrument acquires a time record at a particular offset from the channel being transmitted. When the offset is zero, the instrument is said to be measuring the carrier. For a given offset frequency from the carrier, the transmitter must not exceed a certain power level relative to the carrier. The GSM specification defines the offsets and their maximum absolute and relative power levels.

The general steps in making the measurement are as follows:

1. Acquire time record.
2. Measure power of the carrier.
3. Synchronize for gating on the carrier - finds 50% and 90% portion of burst for Spectrum Due to Modulation portion of the test
4. Compare each offset power to reference to get relative power level.

The output RF spectrum measurement consists of the following two measurements:

- Output RF spectrum due to modulation.
For this measurement the average value during at least 40 bits between bit 87 and 132 (approximately equivalent to the 50% to 90% portion of the burst, excluding midamble) is retained. The vertical lines mark the section of the burst over which the measurement is made. If multiple bursts are examined, an average of the average values is calculated. The relative power (difference between the average power of the burst at zero offset and the average power of the burst at the indicated offset) and the absolute power are displayed.
- Output RF spectrum due to switching transients.
For this measurement the peak value of the burst is retained. If multiple bursts are examined, then the maximum of the peak values is retained. The relative power (difference between the peak power of the burst at zero offset and the peak power of the burst at the indicated offset) and the absolute power are displayed.

The GSM standard specifies the tests are run on specified offsets from the carrier. The instrument identifies this as single offset, multiple offset or swept modes. The measurement made in these modes is the same, except for the following:

- Multiple offset mode automatically makes the measurement at all the specified offset frequencies and lists the results in a table at the end of the measurement.
- Swept mode makes the measurement in the frequency domain and shows the GSM burst relative to the limits mask.

Making the Measurement

1. Press the **Measure** key.
2. Press the **Output RF Spectrum** key.

Factory default parameter settings provide a GSM compliant measurement. For special requirements, you may need to change default settings:

- Mode setup and frequency/channel parameters. Use the **Mode Setup** and **Frequency Channel** keys to change these parameters for all measurements made within the current mode. For further information refer to Chapter 1 of this document.
- Measurement setup parameters. These are measurement specific parameters changed using the Measurement setup (**Meas Setup**) menu. Parameters can be returned to default settings at any time by pressing **Meas Setup, More (1 of 2)** and **Restore Meas Defaults**. For further information on measurement setup parameters, refer to Chapter 5 of the User's Guide for the ESA Series Spectrum Analyzers GSM Measurement Personality.

The following keys provide useful measurement functionality:

- Changing between multiple, single and swept modes:
Press **Meas Setup** followed by **Meas Method**.
- Changing between modulation and switching:
Press **Meas Setup** followed by **Meas Type**
- To change the table display:
The table display can be changed to display results, the GSM specification limits, or the margins. Press the **Display** front panel key followed by the **Table Display** menu key to toggle between these settings.

NOTE

Parameters that exist under the **Meas Setup Advanced** key seldom need to be changed. Any changes from the default values may result in invalid measurement data.

Results

Figure 3-1 **Output RF Spectrum (ORFS) Due To Modulation: Single Offset Measurement**

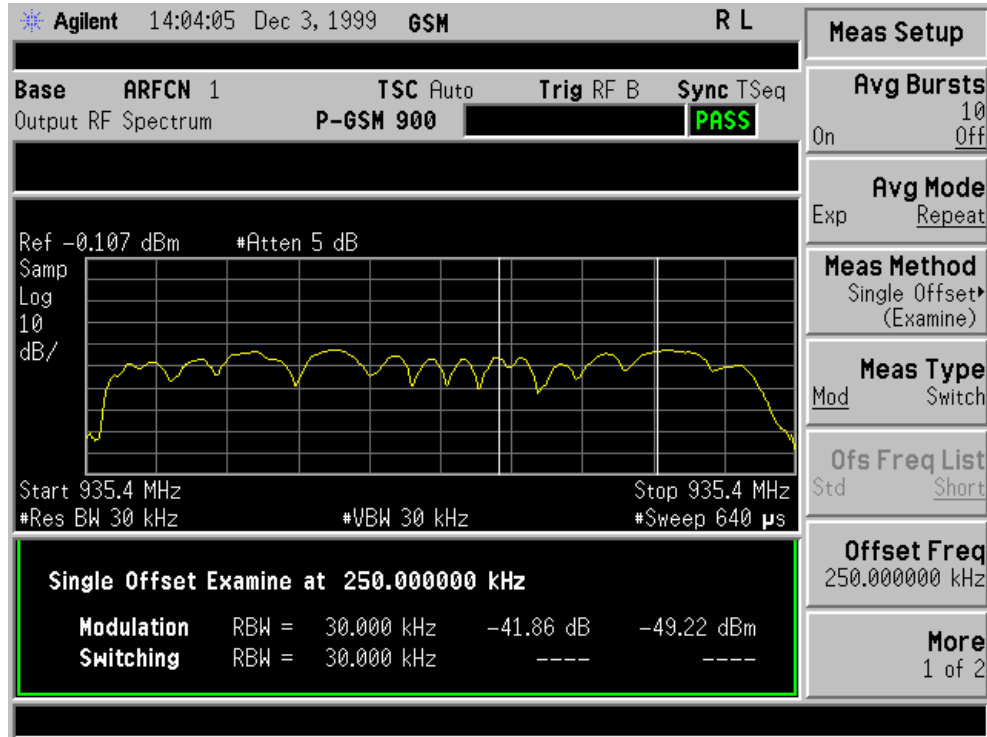

The above figure shows a single offset trace taken during an ORFS due to modulation measurement. The vertical bars show the portion used to measure power due to modulation. If averaging is turned on, the trace is averaged with previous traces using video averaging. The displayed value is the average of points within the vertical bars.

Figure 3-2 Output RF Spectrum (ORFS) Due To Modulation: Multiple Offset Measurement



Figure 3-3 Output RF Spectrum (ORFS) Due To Modulation: Swept Measurement

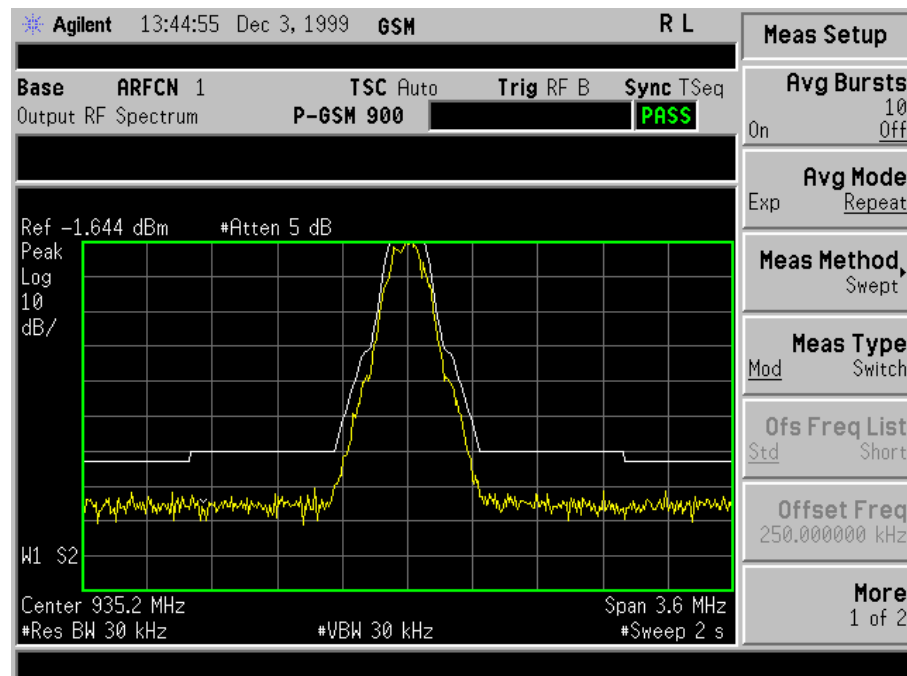
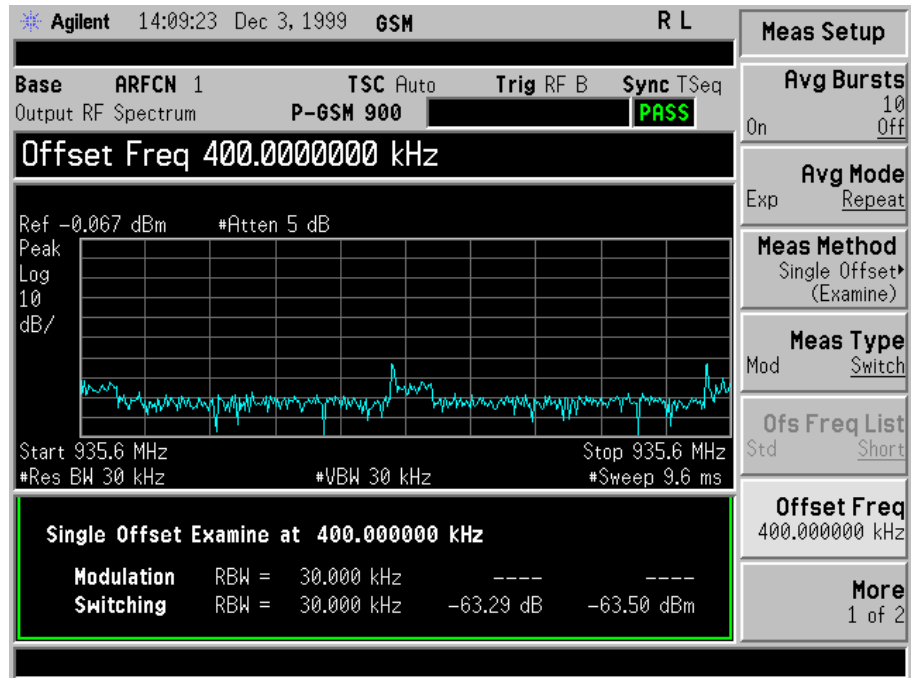

Figure 3-4 **Output RF Spectrum (ORFS) Due To Switching Transients: Single Offset Measurement**



The above figure shows a single offset trace taken during an ORFS due to switching transients measurement. If averaging is turned on, the trace is averaged with previous traces. The peak of the traces is used. The displayed value is the maximum of all points for all traces (Max or Peak) over the entire frame.

Figure 3-5 Output RF Spectrum (ORFS) Due To Switching Transients: Multiple Offset Measurement

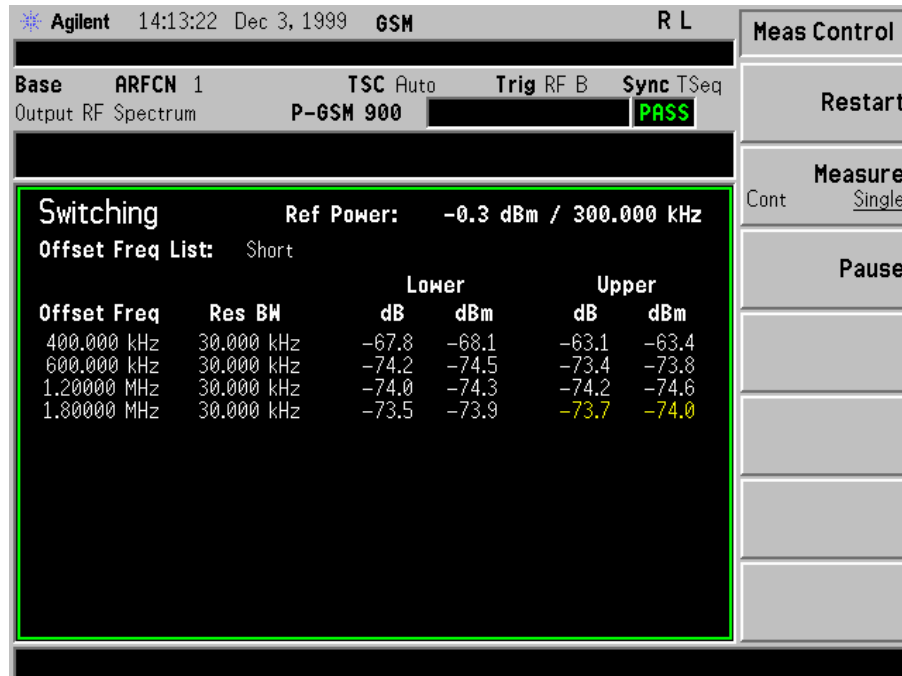
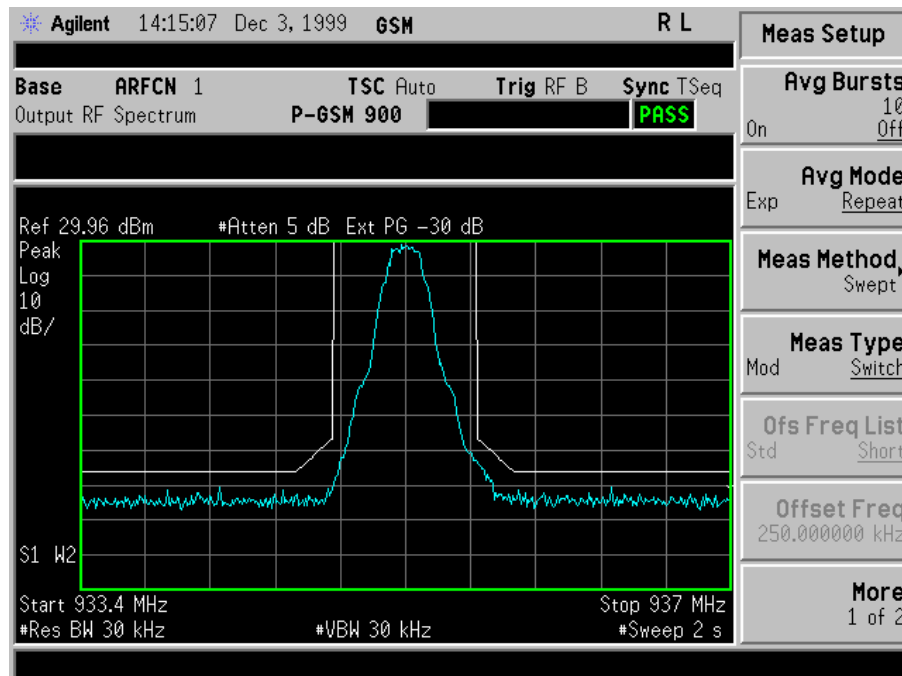

Figure 3-6 Output RF Spectrum (ORFS) Due To Switching Transients: Swept Measurement



Troubleshooting Hints

The Output RF Spectrum measurement, along with the Phase and Frequency Error measurement, can reveal numerous faults in the transmit chain, such as the I/Q baseband generator, filters & modulator.

Making the Phase and Frequency Error Measurement

Purpose

Phase and frequency error measures the modulation quality of GSM systems. Since GSM systems use relative phase to transmit information, phase and frequency accuracy of the GSM transmitter is critical to the system's performance and ultimately affects range.

GSM receivers rely on the phase and frequency quality of the 0.3 GMSK signal in order to achieve the expected carrier to noise performance. A transmitter with high phase and frequency error can often still support phone calls during a functional test. However, it will tend to provide difficulty for mobiles trying to maintain service at the edges of the cell, with low signal levels or under difficult fading and Doppler conditions.

Measurement Method

The phase error of the test signal is measured by computing the difference between the phase of the transmitted signal and the phase of a theoretically perfect signal.

The instrument samples the transmitter output in order to capture the actual phase trajectory. This is then demodulated and the ideal phase trajectory is mathematically derived. Subtracting one from the other results in an error signal.

This measurement allows you to display these errors numerically on the analyzer display. Graphical trace data can also be retrieved remotely by using remote commands. For further information on remote commands refer to the *ESA-E Series Spectrum Analyzers GSM Personality Programming Guide*.

Making the Measurement

1. Press the **Measure** key.
2. Press the **Phase and Frequency** key.

Factory default parameter settings provide a GSM compliant measurement. For special requirements, you may need to change default settings:

- **Mode setup and frequency/channel parameters.**
Use the **Mode Setup** and **Frequency Channel** keys to change these parameters for all measurements made within the current mode. For further information refer to Chapter 1 of this document.

- Measurement setup parameters.
These are measurement specific parameters changed using the Measurement setup (**Meas Setup**) menu. Parameters can be returned to default settings at any time by pressing **Meas Setup, More (1 of 2)** and **Restore Meas Defaults**. For further information on measurement setup parameters, refer to the *ESA Series Spectrum Analyzers GSM Measurement Personality User's Guide*.

Results

Figure 3-7

Phase and Frequency Error Result - Numeric Results

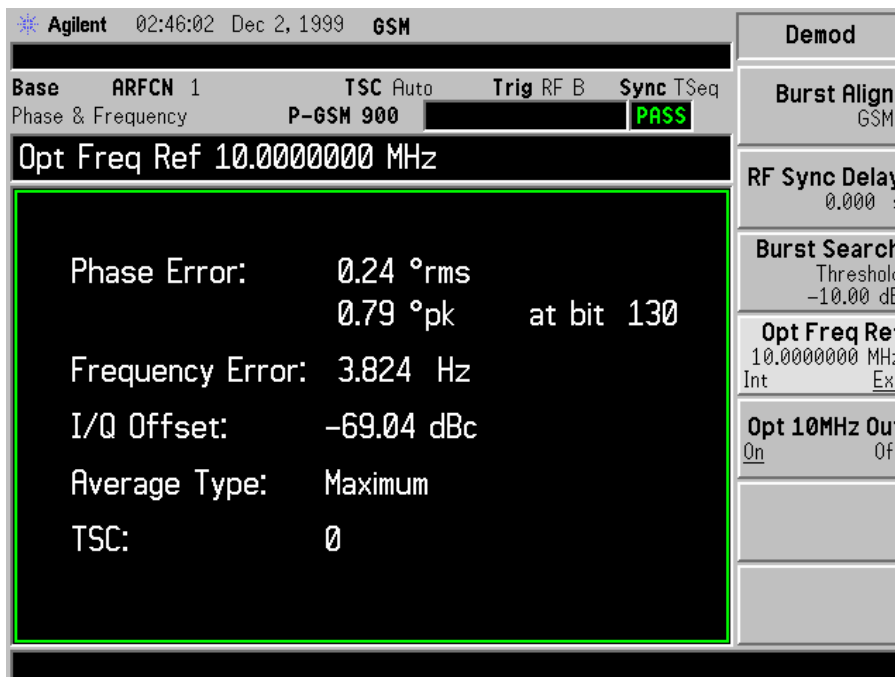

Troubleshooting Hints

Poor phase error indicates a problem with the I/Q baseband generator, filters, or modulator in the transmitter circuitry. The output amplifier in the transmitter can also create distortion that causes unacceptably high phase error. In a system, poor phase error will reduce the ability of a receiver to correctly demodulate, especially in marginal signal conditions. This ultimately affects range.

Occasionally, a Phase and Frequency Error measurement may fail the prescribed limits at only one point in the burst, for example at the beginning. This could indicate a problem with the transmitter power ramp or some undesirable interaction between the modulator and power amplifier.

Making the Power Vs Time Measurement

Purpose

Power vs Time measures the mean transmit power during the “useful part” of GSM bursts and verifies that the bursts fit within the defined mask. This can be used to test that other adjacent timeslots are not experiencing interference. Power vs Time also lets you view more than one burst at a time up to an entire frame.

Measurement Method

The Power vs Time measurement provides masks for both BTS (Base Transceiver Station) and MS (mobile station). The timings are referenced to the transition from bit 13 to bit 14 of the midamble training sequence. The 0 dB reference is determined by measuring the mean transmitted power during the “useful part” of the burst. You can also define a user configurable limit mask to apply to the measured burst. For further information refer to the *ESA-E Series Spectrum Analyzers GSM Measurement Personality User's Guide*.

The GSM specification defines the “useful part” of the normal GSM burst as being the 147 bits centered on the transition from bit 13 to bit 14 (the “T0” time point).

The instrument acquires a GSM signal in the time domain. The “T0” point and the useful part are computed. If Burst Sync is set to **Training Seq**, a GSM demodulation is performed to find “T0”. If Burst Sync is set to **RF Amptd**, an approximation of “T0” will be used without performing a demodulation. The average power in the useful part is then computed and displayed, and the GSM limit mask is applied. The measurement displays **PASS** when the burst fits within the bounds of the mask.

Making the Measurement

1. Press the **Measure** key.
2. Press the **Power vs Time** key.

Factory default parameter settings provide a GSM compliant measurement. For special requirements, you may need to change default settings:

- **Mode setup and frequency/channel parameters.**
Use the **Mode Setup** and **Frequency Channel** keys to change these parameters for all measurements made within the current mode. For further information refer to Chapter 1 of this document.
- **Measurement setup parameters.**
These are measurement specific parameters changed using the Measurement setup (**Meas Setup**) menu. Parameters can be returned to default settings at any time by pressing **Meas Setup, More (1 of 2)** and **Restore Meas Defaults**. For further information on measurement setup parameters, refer to Chapter 5 of the *ESA-E Series Spectrum Analyzers GSM Measurement Personality User's Guide*.

NOTE

Parameters that exist under the **Meas Setup Advanced** key seldom need to be changed. Any changes from the default values may result in invalid measurement data.

Power vs Time Custom Masks

For the Power vs Time measurement, you can define a user configurable limit mask to apply to the measured burst. This feature can only be accessed via SCPI commands. For further information refer to the *ESA-E Series Spectrum Analyzers GSM Measurement Personality Programming Guide*.

Results

Figure 3-8 Power vs Time Measurement Result - Mask View

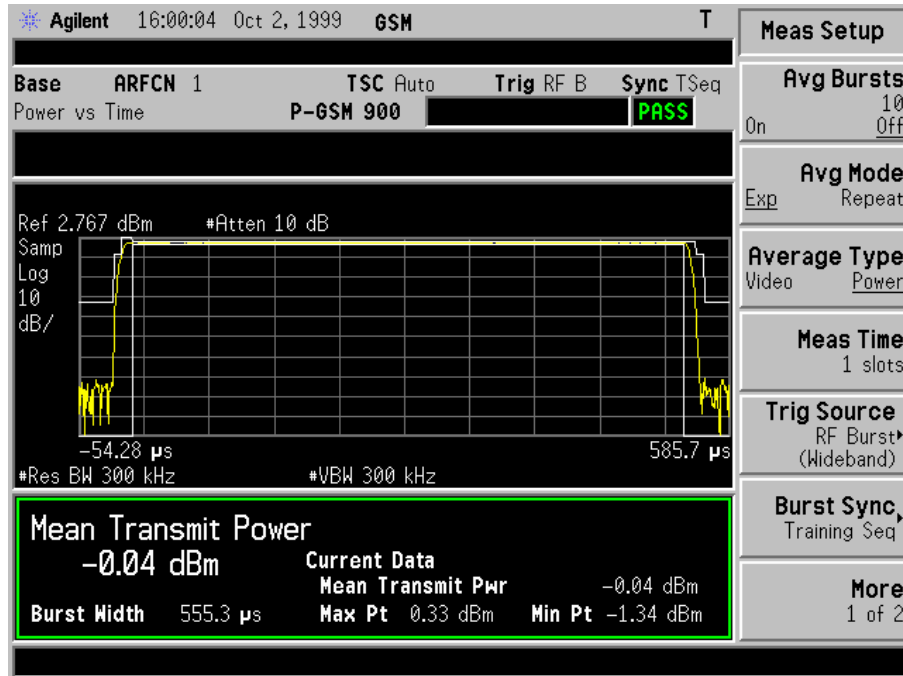
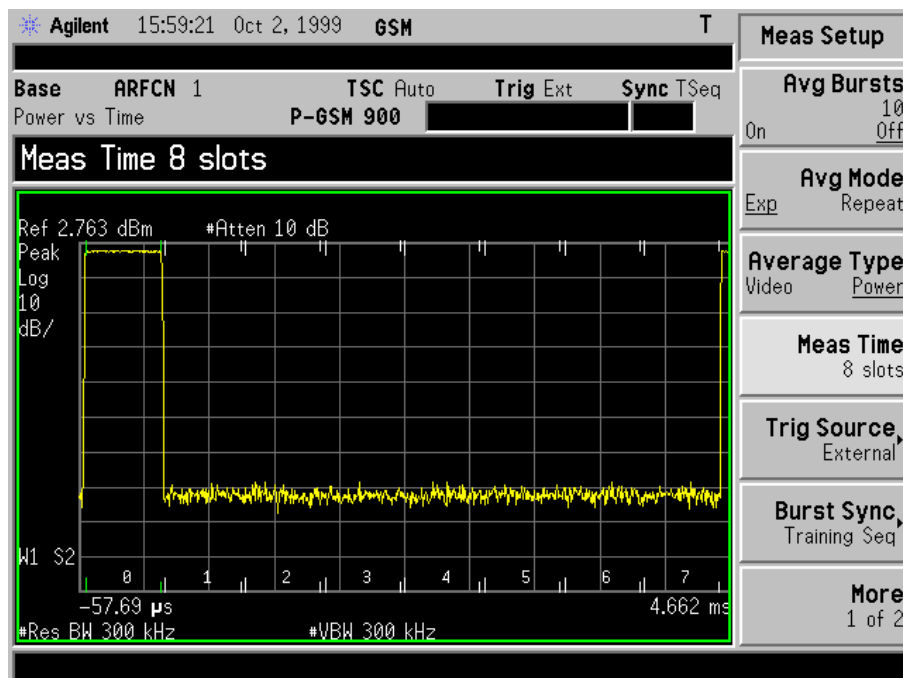

Figure 3-9 Power vs Time Measurement Result - Monitor View



Changing the View

The **View/Trace** key will access a menu which allows you to select the desired view of the measurement from the following selections:

- **Mask** - views the entire sweep as specified by the meas time and compares the burst against a predefined mask.
- **Monitor** - views the entire sweep as specified by the meas time and displays frame structure annotation. A Max Hold function is provided to allow monitoring over time.

Changing the Display

The **Display** key allows you to turn the limit mask on and off. This also disables the mask limit test, but still calculates the power in the useful part.

Troubleshooting Hints

If a transmitter fails the Power vs Time measurement this usually indicates a problem with the units output amplifier or leveling loop.

Making The Power Steps Measurement

Purpose

The power steps measurement uses long sweep times to display the different power steps resulting from adaptive control. It measures the dynamics of the power step changes. Use the more accurate mean carrier power measurement to make power measurements on carriers with a static power level. The power steps measurement checks the maximum power of all 8 timeslots.

SFH mode is available for this measurement.

An external frame trigger is not required for this measurement

Measurement Method

Base box markers are placed on the trace and the marker mode set to delta. The marker delta readings give the difference in amplitude and time between the power levels of the markers.

Averaging is not enabled for the power steps measurement—it is not appropriate due to the long sweep time and manual power steppings.

Making the Measurement

1. Press the **Measure** key.
2. Ensure the carrier level to be measured is set to the maximum power step level. The power steps measurement performs the auto level routine upon entering the measurement, positioning the signal level at the top of the screen.
3. Press the **Power Steps** key.

Factory default parameter settings provide a GSM compliant measurement. For special requirements, you may need to change default settings:

- Mode setup and frequency/channel parameters.
Use the **Mode Setup** and **Frequency Channel** keys to change these parameters for all measurements made within the current mode. For further information refer to Chapter 1 of this document.

- Measurement setup parameters.
 These are measurement specific parameters changed using the Measurement setup (**Meas Setup**) menu. Parameters can be returned to default settings at any time by pressing **Meas Setup** and **Restore Meas Defaults**. For further information on measurement setup parameters, refer to the *ESA-E Series Spectrum Analyzers GSM Measurement Personality User's Guide*.

NOTE Parameters that exist under the **Meas Setup Advanced** key seldom need to be changed. Any changes from the default values may result in invalid measurement data.

Results

Figure 3-10 Power Steps Measurement

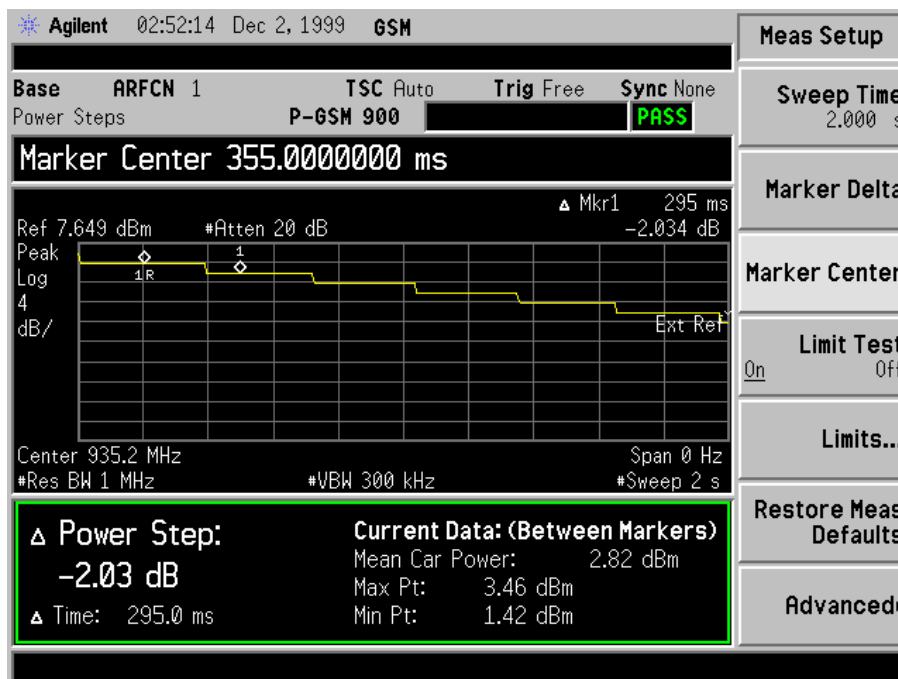

Making the Transmitter Power Measurement

Purpose

Transmitter Power is the measure of in-channel power for GSM systems. Mobile stations and base transceiver stations must transmit enough power, with sufficient modulation accuracy, to maintain a call of acceptable quality without leaking into frequency channels or timeslots allocated for others. GSM systems use dynamic power control to ensure that each link is maintained with minimum power. This gives two fundamental benefits: overall system interference is kept to a minimum and, in the case of mobile stations, battery life is maximized.

The Transmitter Power measurement determines the average power for an RF signal burst at or above a specified threshold value. The threshold value may be absolute, or relative to the peak value of the signal.

At the base transceiver station, the purpose of the Transmitter Power measurement is to determine the power delivered to the antenna system on the radio-frequency channel under test. The Transmitter Power measurement verifies the accuracy of the mean transmitted RF carrier power. This can be done across the frequency range and at each power step.

Measurement Method

The instrument acquires a GSM signal in the time domain. The average power level above the threshold is then computed and displayed. This measurement uses the “power-above-threshold” method instead of the “useful part of the burst” method defined in the GSM standards. The measured Transmitter Carrier Power will be very nearly the same for these two methods. The power-above-threshold method has the advantages of being faster and allows power measurements to be made at somewhat lower power levels. It also has the advantage of not requiring the carrier to have a valid TSC (Training Sequence Code).

Note that this measurement does not provide a way to specify which timeslot is to be measured. Therefore if multiple timeslots are on, they should all be set at the same power level, or the levels of those timeslots to be excluded need to be kept below the threshold level. If you want to measure Transmitter Carrier Power using the GSM specified useful part of the burst method, use the Power vs Time measurement, which also measures the power ramping of the burst.

Making the Measurement

1. Press the **Measure** key.
2. Press the **Transmitter Power** key.

Factory default parameter settings provide a GSM compliant measurement. For special requirements, you may need to change default settings:

- **Mode setup and frequency/channel parameters.**
Use the **Mode Setup** and **Frequency Channel** keys to change these parameters for all measurements made within the current mode. For further information refer to Chapter 1 of this document.
- **Measurement setup parameters.**
These are measurement specific parameters changed using the Measurement setup (**Meas Setup**) menu. Parameters can be returned to default settings at any time by pressing **Meas Setup, More (1 of 2)** and **Restore Meas Defaults**. For further information on measurement setup parameters, refer to the *ESA Series Spectrum Analyzers GSM Measurement Personality User's Guide*.

NOTE

Parameters that exist under the **Meas Setup Advanced** key seldom need to be changed. Any changes from the default values may result in invalid measurement data.

Results

Figure 3-11 Transmitter Power Result - Single Burst

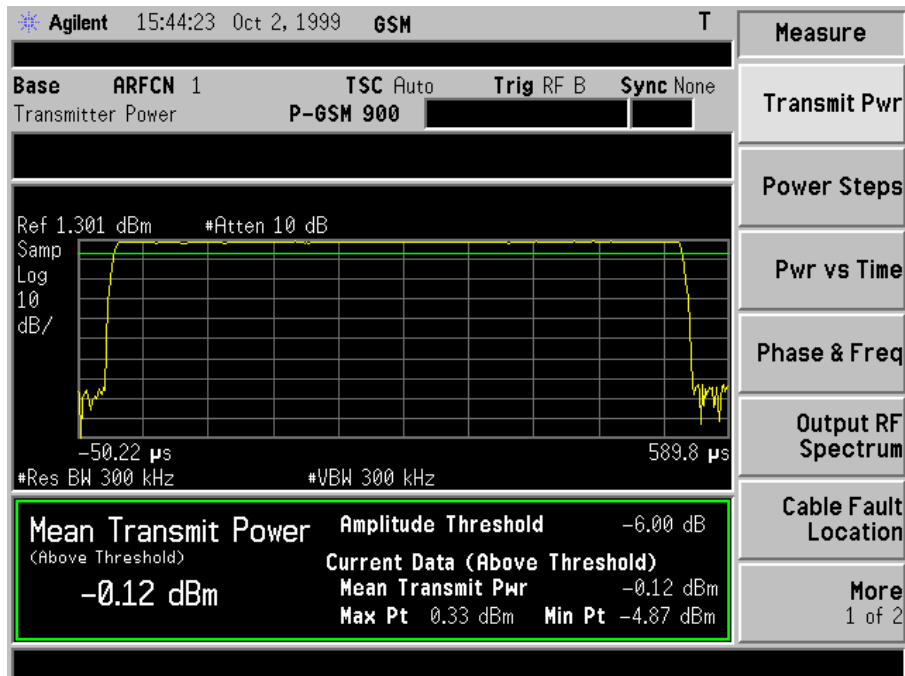
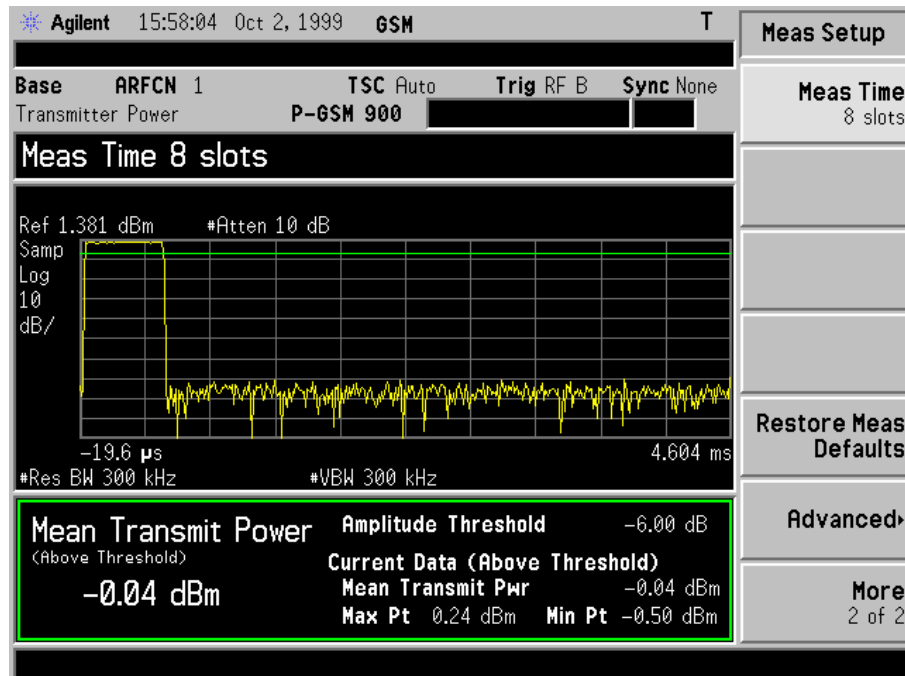

Figure 3-12 Transmitter Power Result - Multiple Bursts



Troubleshooting Hints

Low output power can lead to poor coverage and intermittent service for phone users. Out of specification power measurements indicate a fault usually in the power amplifier circuitry. They can also provide early indication of a fault with the power supply, that is the battery in the case of mobile stations.

4 Making GSM Air Interface Measurements

Chapter Contents

This chapter details how to make GSM air interface measurements. The following measurements are described:

- Monitor band/channel.
- Out of band spurious.
- Transmitter receive band spurious.
- Transmitter transmit band spurious.
- Transmitter power.

Making the Monitor Band/Channel Measurement

Purpose

This measurement verifies the GSM band and channels are free of interference by measuring the spurious signals in the bands and channels specified by the selected standard and tuning plan.

Measurement Method

This procedure scans the specified band or channels and by placing markers on the trace it is possible to check the band/channels for interference. A Max Hold function enables monitoring over time. This is useful when the interference is intermittent.

Making the Measurement

1. Press the **Measure** key.
2. Press the **Monitor Band/Channel** key.

Factory default parameter settings provide a GSM compliant measurement. For special requirements, you may need to change default settings:

- **Mode setup and frequency/channel parameters.**
Use the **Mode Setup** and **Frequency Channel** keys to change these parameters for all measurements made within the current mode. For further information refer to Chapter 1 of this document.
- **Measurement setup parameters.**
These are measurement specific parameters changed using the Measurement setup (**Meas Setup**) menu. Parameters can be returned to default settings at any time by pressing **Meas Setup, More (1 of 2)** and **Restore Meas Defaults**. For further information on measurement setup parameters, refer to the *ESA-E Series Spectrum Analyzers GSM Measurement Personality Use's Guide*.

NOTE

Parameters that exist under the **Meas Setup Advanced** key seldom need to be changed. Any changes from the default values may result in invalid measurement data.

Results

Figure 4-1 Monitor Band/Channel Measurement Results—Band Method

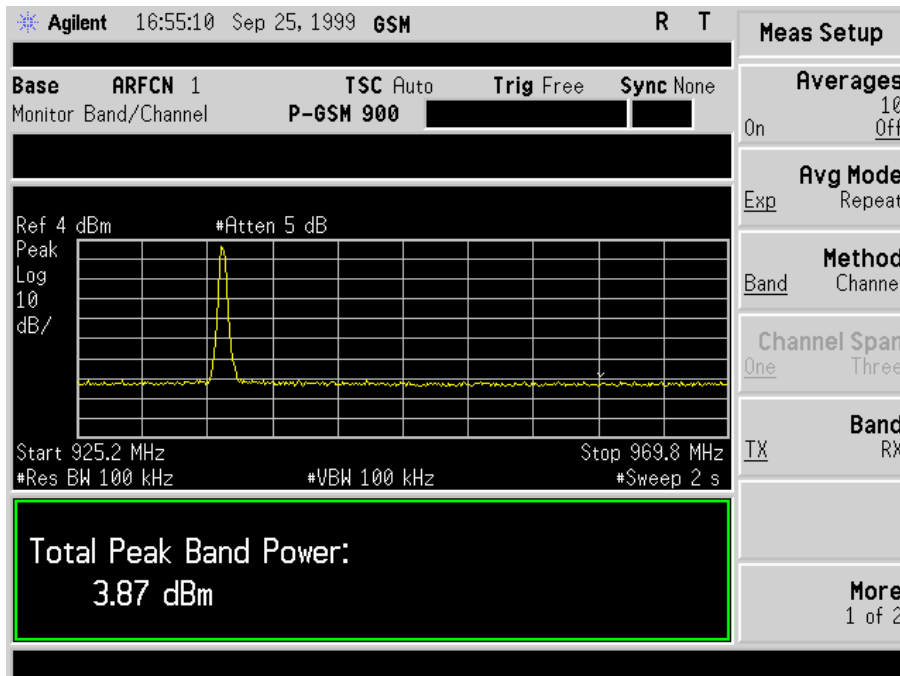
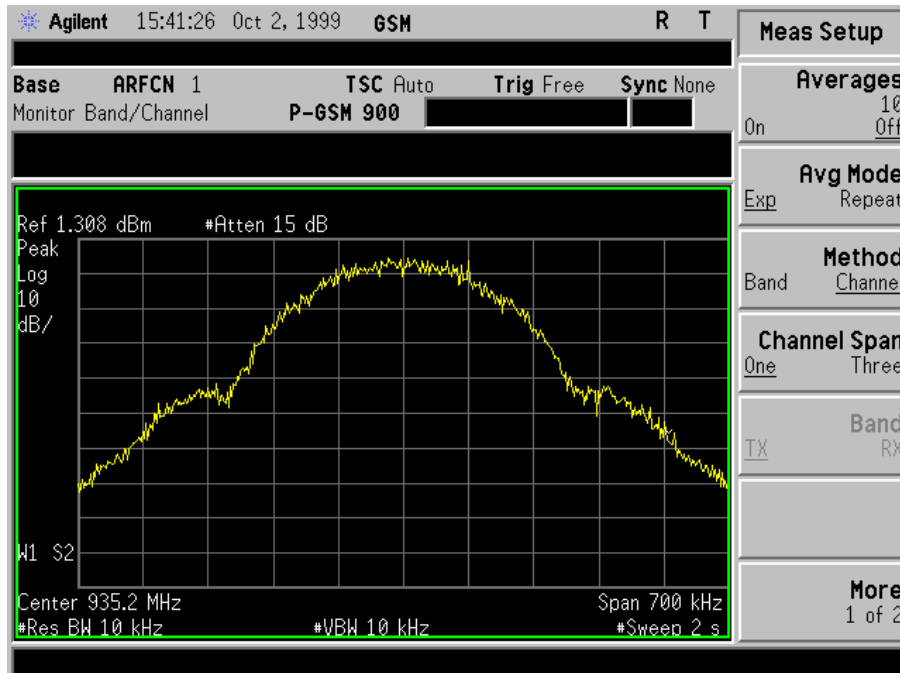

Figure 4-2 Monitor Band/Channel Measurement Results—Channel Method



Troubleshooting Hints

- If an external attenuator is used, be sure to include the attenuation value in the measurement. This can be done under the Input/Output key.
- If an preamplifier is used, be sure to include the gain value in the measurement. This can be done under the Input/Output key.

Making the Out-of-Band Spurious Measurement

Purpose

This measurement verifies the operation of the transmitter by measuring the spurious signals created out side of the transmitter band specified by the selected standard and tuning plan.

Measurement Method

This out-of-band spurious measurement first measures the channel power as defined by the selected standard and tuning plan. Then out of band frequencies are scanned and spurious responses are measured in accordance with the standards documents. If a carrier is not present, the measurement runs and the message “Carrier Not Present” is displayed.

Although the standards documents specify that frequencies up to 12.75 GHz are scanned, not all ESA models are equipped to measure at these frequencies. In such cases, frequencies up to the maximum range of the analyzer are used.

Making the Measurement

1. Press the **Measure** key.
2. Press the **Out Of Band Spurious** key.

Factory default parameter settings provide a GSM compliant measurement. For special requirements, you may need to change default settings:

- **Mode setup and frequency/channel parameters.**
Use the **Mode Setup** and **Frequency Channel** keys to change these parameters for all measurements made within the current mode. For further information refer to Chapter 1 of this document.
- **Measurement setup parameters.**
These are measurement specific parameters changed using the Measurement setup (**Meas Setup**) menu. Parameters can be returned to default settings at any time by pressing **Meas Setup, More (1 of 2)** and **Restore Meas Defaults**. For further information on measurement setup parameters, refer to the *ESA-E Series Spectrum Analyzers GSM Measurement Personality User's Guide*.

NOTE Parameters that exist under the **Meas Setup Advanced** key seldom need to be changed. Any changes from the default values may result in invalid measurement data.

Results can be more closely inspected using parameters accessed by the **Frequency, Span and Amplitude** front panel keys.

Results

Figure 4-3 Out-of-Band Spurious Measurement Results

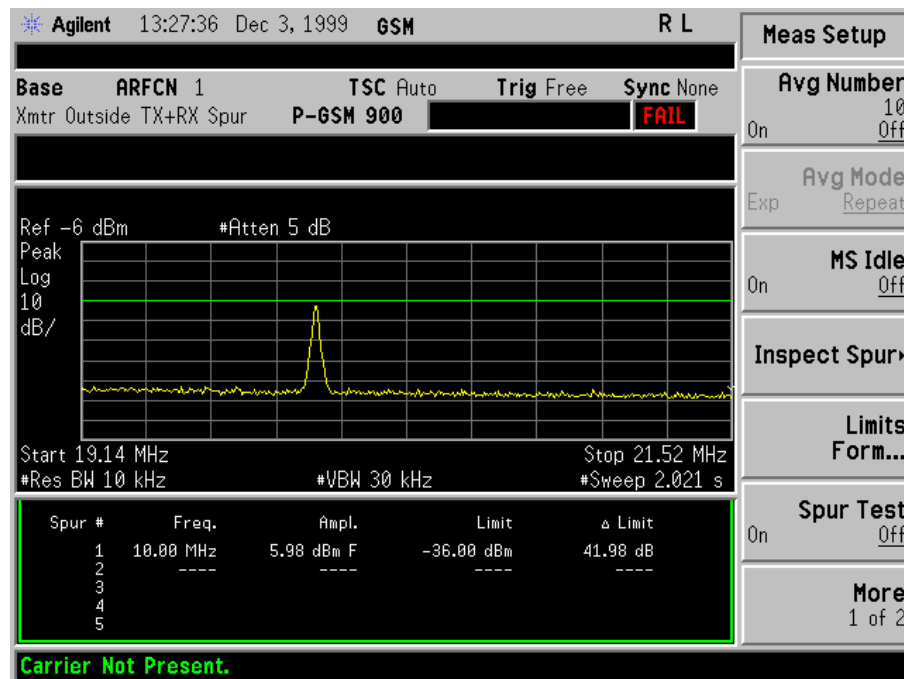

NOTE Results are shown in tabular format beneath the trace. To view this section of the window in its entirety, press the **Next Window** menu key until it is highlighted, then press the **Zoom** menu key.

Inspecting Results

1. Select a specific spur:
 - Press **Meas Setup, Inspect Spur** and **Inspect Spur ON**. If any spurs have been measured, the current spur number is highlighted in the results table.
 - Move up and down the list of spurs using the numeric keypad or tab keys.

2. Inspect a specific spur by using:

- Parameters contained under the **Frequency, Span and Amplitude** front panel keys.
- **Sweep Time, Res BW and Video BW** parameters, contained under **Meas Setup, Inspect Spur**.

Troubleshooting Hints

- If an external attenuator is used, be sure to include the attenuation value in the measurement. This can be done under the **Input, Ext Atten** menu.
- If an external preamplifier is used, be sure to include the gain value in the measurement. This can be done under the **Input, Ext Gain** menu.

Making The Transmitter Receive (Rx) Band Spurious Measurement

Purpose

The receive band spurious measurement checks a transmitter's receive band for conformance to the ETSI specification:

Table 4-1 ETSI Specification: Maximum Permissible Transmit Power (dB)

	P-GSM900	E-GSM90	R-GSM900	DCS1800	PCS1900
MS	-79.0	-67.0	-60.0	-71.0	-71.0
BTS	-98.0	-98.0	-89.0	-98.0	-98.0
BTS M1	-91.0	-91.0	-91.0	-96.0	-96.0
BTS M2	-86.0	-86.0	-86.0	-91.0	-91.0
BTS M3	-81.0	-81.0	-81.0	-86.0	-86.0

NOTE

For MS mode, the limits for E-GSM900 and R-GSM900 apply only to the part of the limit that does not overlap with other bands. The P-GSM900 limit takes priority for the upper portion followed by E-GSM900 and then R-GSM900, if appropriate. This means that up to three limits may be in force at once in MS mode.

Measurement Method

The measurement sweeps in the receive band of the current device and checks the trace for any spurs which exceed the maximum permissible transmitter power (shown above in [Table 4-1](#)).

Making the Measurement

1. Press the **Measure** key.
2. Press the **Rx Band Spur** key.

The following cautionary information form is displayed:

Figure 4-4 Rx Band Spurious Measurement Cautionary Information Form

Agilent 16:02:56 Oct 2, 1999 GSM T

Rx Band Spurious Setup

Preamp Gain 20.00 dB

CAUTION: TO AVOID ANALYZER DAMAGE!

Connect a receive band (890.20 to 914.80 MHz) bandpass filter (BPF) between the transmitter output and the analyzer input. The total carrier power applied to the analyzer MUST be < +20 dBm. The input power should be kept < -10 dBm for correct results.

Preamp Gain 20.00 dB

RF Input (50ohm)

Transmitter BPF Preamp

A preamplifier following the BPF is required for optimum sensitivity. Set the value of the preamp gain parameter to be the combined value of BPF loss, external preamp gain, and cable loss. Pressing 'Continue' will set the attenuator to 0 dB.

Preamp Gain 20.00 dB

Int Preamp On Off

Continue

Cancel

CAUTION

The spectrum analyzer is vulnerable to damage at the input if the above cautionary information is not observed before continuing with the measurement.

- a. Connect a receive band bandpass filter (BPF) between the transmitter output and the analyzer input. This is required as the total carrier power applied to the analyzer must be < +20 dBm and to achieve correct results the input power must be kept at < -10 dBm.
- b. Connect a preamplifier following the BPF. This can be either external or internal. If an internal preamp is not fitted the Int Preamp option is grayed out. This is required to achieve optimum sensitivity.
- c. Enter a preamp gain value.
- d. Press **Continue**.

Factory default parameter settings provide a GSM compliant measurement. For special requirements, you may need to change default settings:

- Mode setup and frequency/channel parameters.
 Use the **Mode Setup** and **Frequency Channel** keys to change these parameters for all measurements made within the current mode. For further information refer to Chapter 1 of this document.
- Measurement setup parameters.
 These are measurement specific parameters changed using the measurement setup (**Meas Setup**) menu. Parameters can be returned to default settings at any time by pressing **Meas Setup**, and **Restore Meas Defaults**. For further information on measurement setup parameters, refer to the *ESA-E Series Spectrum Analyzers GSM Measurement Personality User's Guide*.

NOTE

Parameters that exist under the **Meas Setup Advanced** key seldom need to be changed. Any changes from the default values may result in invalid measurement data.

Results

Figure 4-5 Transmitter Rx Band Spurious Measurement Results

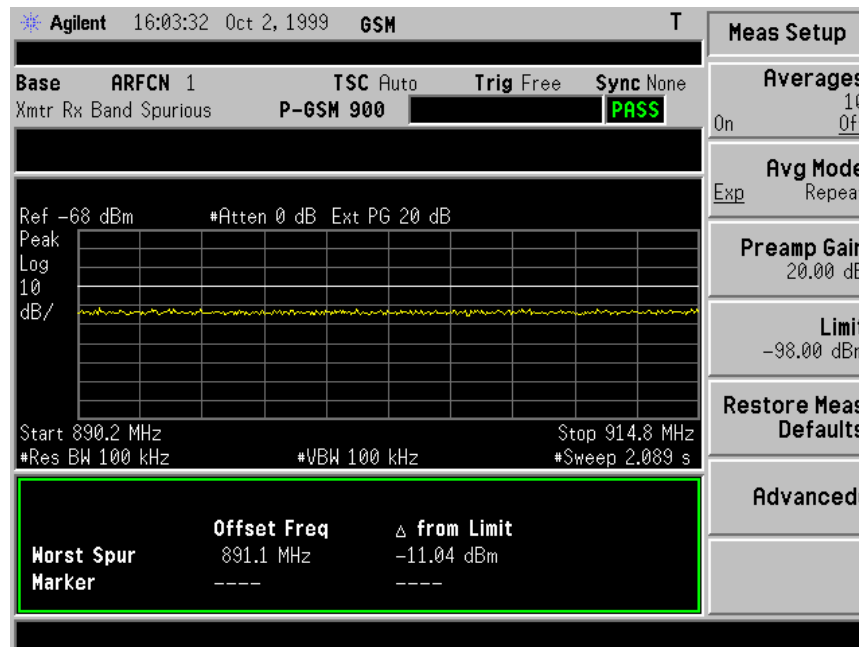

Inspecting Results

Results are displayed according to the following categories:

Table 4-2 Transmitter Rx Band Spurious Measurement Result Categories

Result category	Units	Min	Max	Description
Worst spur frequency	Hz	N/A	N/A	Displays the frequency of the highest peak from all segments, or from the current segment if in examine mode.
Worst spur amplitude	dB	-200	100	Displays the amplitude of the highest peak from all segments, or from the current segment if in Examine mode.
Marker frequency	Hz	N/A	N/A	Displays the frequency of the active marker. Disabled if no markers are active.
Marker amplitude	dB	-200	100	Displays the amplitude of the active marker. Disabled if no markers are active.

Troubleshooting Hints

- If an external attenuator is used, be sure to include the attenuation value in the measurement. This can be done under the **Input, Ext Atten** menu or by using a negative value for **Meas Setup Preamp Gain**.
- If an preamplifier is used, be sure to include the gain value in the measurement.

Making the Transmitter Transmit (Tx) Band Spurious Measurement

Purpose

The transmit band spurious measurement checks a transmitter's transmit band for conformance to the ETSI specification:

Table 4-3 ETSI Specification: Maximum Permissible Transmit Power (dBm)

	P-GSM900	E-GSM90	R-GSM900	DCS1800	PCS1900
MS (idle)	-59.0	-59.0	-59.0	-53.0	-53.0
MS (active)	-36.0	-36.0	-42.0	-36.0	36.0
BTS	-36.0	-36.0	-36.0	-36.0	36.0

NOTE Although the Idle Mode parameter has no effect when testing in BTS mode, the parameter should always be set to the relevant setting (Idle Mode = ON or OFF) so that the measurement knows which limit to use.

Measurement Method

The measurement splits the transmit band into four segments (or less if the currently selected ARFCN is at the edge of the band) and allocates analyzer parameters for each segment.

Two measurement modes are provided:

- **Full:** Each segment is swept and the peak trace point amplitude and frequency stored. The maximum of these peaks is taken as the worst spur and checked against a user definable limit parameter to see whether or not the spur fails the test.
- **Examine:** A single full measurement is performed, the measurement then parking on the segment containing the worst spur.

NOTE If the measurement is set to sweep mode single, or if the measurement mode is examine, you can examine each segment individually using the View menu keys.

Making the Measurement

1. Press the **Measure** key.
2. Press the **Tx Band Spur** key.

Factory default parameter settings provide a GSM compliant measurement. For special requirements, you may need to change default settings:

- Mode setup and frequency/channel parameters.
Use the **Mode Setup** and **Frequency Channel** keys to change these parameters for all measurements made within the current mode. For further information refer to Chapter 1 of this document.
- Measurement setup parameters.
These are measurement specific parameters changed using the Measurement setup (**Meas Setup**) menu. Parameters can be returned to default settings at any time by pressing **Meas Setup** and **Restore Meas Defaults**. For further information on measurement setup parameters, refer to the *ESA-E Series Spectrum Analyzers GSM Measurement Personality User's Guide*.

NOTE

Parameters that exist under the **Meas Setup Advanced** key seldom need to be changed. Any changes from the default values may result in invalid measurement data.

Results

Figure 4-6

Transmitter Tx Band Spurious Measurement Results

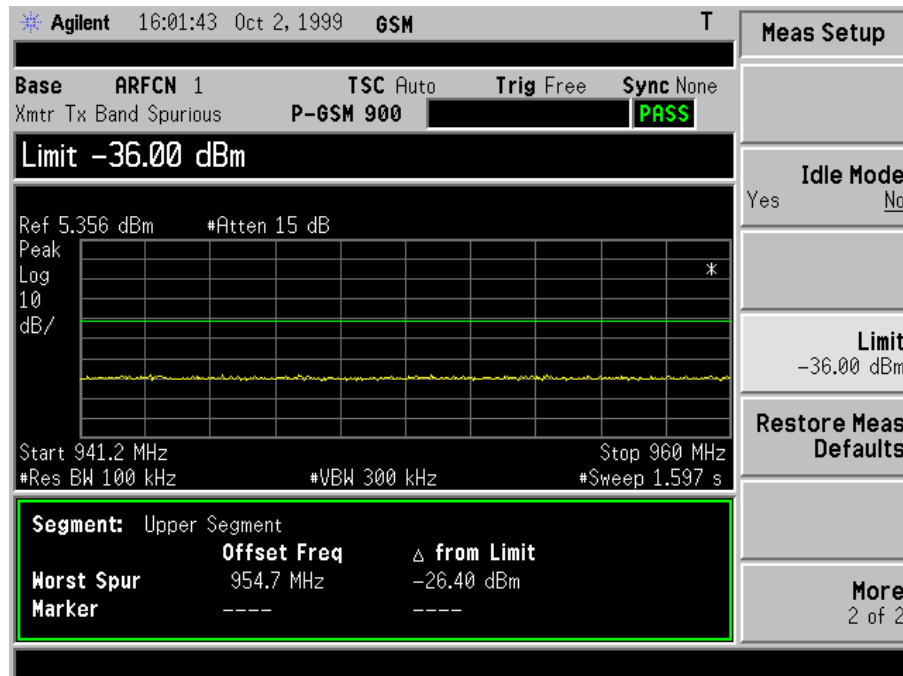

Inspecting Results

Results are displayed according to the following categories:

Table 4-4 Transmitter Tx Band Spurious Measurement Result Categories

Result category	Unit	Min	Max	Description
Worst spur frequency	Hz	N/A	N/A	Displays the frequency of the highest peak from all segments, or from the current segment if in examine mode).
Worst spur amplitude	dB	-200	100	Displays the amplitude of the highest peak from all segments, or from the current segment if in Examine mode.
Marker frequency	Hz	N/A	N/A	Displays the frequency of the active marker. Disabled if no markers are active.
Marker amplitude	dB	-200	100	Displays the amplitude of the active marker. Disabled if no markers are active.

Troubleshooting Hints

- If an external attenuator is used, be sure to include the attenuation value in the measurement. This can be done under the **Input, Ext Atten** menu.
- If an preamplifier is used, be sure to include the gain value in the measurement. This can be done under the **Input** key.

Making the Transmitter Power Measurement

This measurement is detailed in Chapter 3, Making GSM Base Station Measurements.

5

**Making GSM Cable and Antenna
Measurements**

Chapter Contents

This chapter details how to make GSM cable and antenna measurements. The following measurements are described:

- Cable fault location (performed in GSM mode).
- Return loss (VSWR) (performed in SA mode).
- Loss/gain (Transmit band LNA gain and flatness/receive band combiner loss and flatness) (performed in SA mode).

NOTE

The return loss (VSWR) and loss/gain measurements are not “one button” measurements. All steps required to run them are fully detailed in this chapter.

Making Cable Fault Location Measurements

Purpose

A cable fault location measurement displays the reflected signal of a transmission line as a function of the distance down the line. This complements the return loss measurement described in the previous section: if a cable under test fails a return loss measurement, a cable fault location measurement can be used to identify the location of the fault. The measurement is particularly useful when a base station and antenna are connected by a long length of cable.

Example

NOTE A return loss measurement requires the use of a power divider.

1. Enter GSM mode and access the measurement.
 - a. Press the **Mode** front panel key.
 - b. Press the **GSM** menu key.
 - c. Press the **Cable Fault Location** menu key.
 - d. Connect up the equipment as prompted by the dialog box and illustrated in Figure 5-1.

Figure 5-1 Cable Fault Location Measurement Set-up

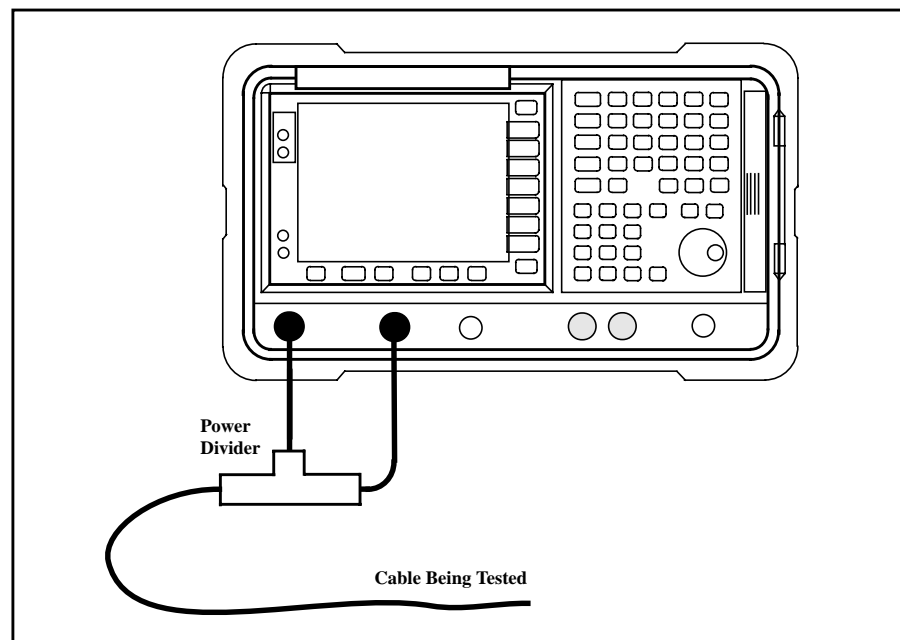

2. Configure the spectrum analyzer for the appropriate cable type.
 - a. Press the **Cable Type** menu key.
 - b. Page through available cable types using the **tab**, **RPG**, or **Step** keys.
 - c. Press the **Select** menu key to select the appropriate cable type.
3. Set up a maximum range value just greater than the length of the cable to be tested:
 - a. Press the **Max Range** menu key.
 - b. Enter the appropriate value using the numeric key pad.
4. Calibrate the spectrum analyzer.

Calibration removes any errors introduced by the cabling and components of the test setup before making the measurement.

NOTE

Press the **Esc** front panel key to cancel this procedure at any stage.

- a. Disconnect the cable to be tested.
- b. Press the **Meas Setup** front panel key.
- c. Press the **Calibrate** menu key.

Connect an open to the analyzer via the power divider as prompted (see Figure 5-2).
- d. Press the **Calibrate** menu key.

Connect a short to the analyzer via the power divider as prompted (see figure 5-2).
- e. Press the **Calibrate** menu key.
- f. Re-connect the cable to be tested in place of the short/open, as prompted by the dialog box.
- g. Press the **Esc** front panel key to remove the dialog box and end the calibration procedure.

Figure 5-2 Calibrating the spectrum analyzer for cable fault location

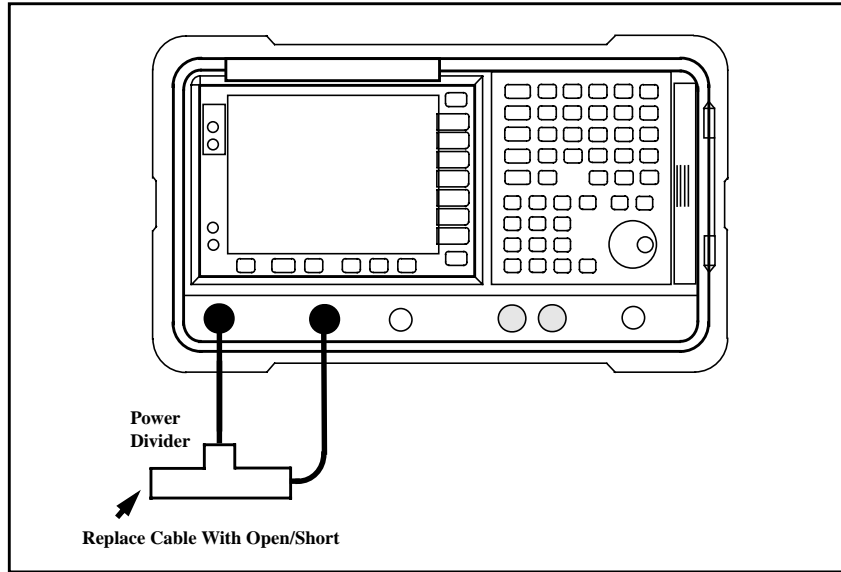

5. Make the measurement.

Read the measurement and save it if required.

The result is shown on the screen. Press the **Marker** front panel key to move the marker to the fault(s) of interest. An example is shown in figure 5-3.

Figure 5-3 Example Cable Fault Location Measurement Screen

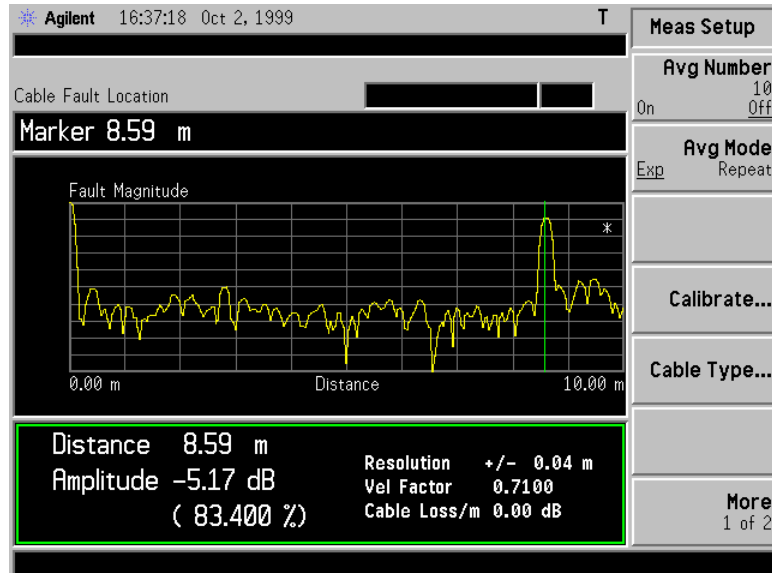

Trace Points

Changing the number of trace points in the cable fault affects the minimum and maximum measurable distances. As a general rule, the longer the cable, the more trace points you should use. Up to 8192 trace points can be used but due to the computationally intensive FFT, the measurement becomes slower as the number of points used increases. To ensure the fastest possible measurement speed, always use a number of trace points equal to the power of 2—for example 512 or 1024.

FFT Windowing Function

The cable fault location measurement uses an FFT to convert the analyzer frequency trace into a distance trace. To get the best results from the FFT you must apply the most suitable windowing function to the frequency trace before performing the FFT. The following table describes the windowing functions available:

Table 5-1 Windowing Functions Available for the Cable Fault Location Measurement

Function	Description	Max side-lobe level	Side-lobe roll off	Max main
Rectangular	The function results in no windowing.	-13.261 dB	20 dB/decade	-3.9224d
Flat Top	The default value. A five term flat top window. A good window to use when making amplitude measurements of relatively pure tones.	-95.1 dB		+/- 0.0020
Gaussian	A five term cosine window which resembles a Gaussian window.	-125.4 dB		-0.680056
Hanning	A window which has good frequency resolution and reasonably good side lobe-lobe roll-off, but poor main-lobe flatness and relatively large side-lobe peaks.	-31.46730784	60 dB/decade	-1.423622

Making Return Loss Measurements

Purpose

Some of the energy incident upon a device can be reflected back towards the source. A return loss measurement quantifies this reflected energy. Return loss is used to determine the health of an antenna system and its associated cabling by measuring the amount of transmitted power reflected back from the antenna system and therefore not passed over the air interface to the mobile user.

Cables and antennae are often subjected to harsh weather conditions resulting in a performance which deteriorates over time, leading to an eventual failure. By monitoring return loss over time, cable and antennae performance can be monitored and preventive action taken when required.

Making the measurement

NOTE A return loss measurement requires the use of a signal separation device such as a directional coupler or bridge in addition to the device being tested for return loss.

NOTE The spectrum analyzer must be in spectrum analyzer mode for this measurement.

1. Connect the tracking generator, signal separation device, device being measured and the spectrum analyzer input as shown in Figure 5-4

Figure 5-4 Return Loss Measurement Set-up

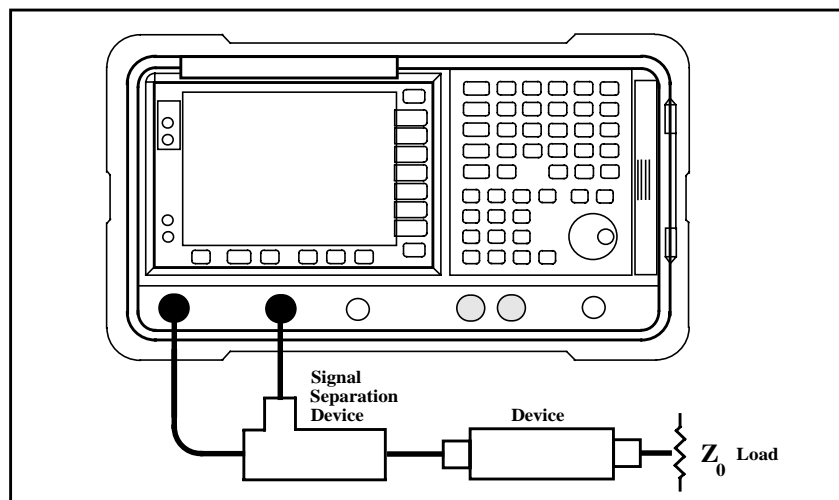

2. Turn on the tracking generator.
 - a. Press the **Source** front panel key.
 - b. Press the **Amplitude** menu key so that the tracking generator is turned on.
 - c. Set an amplitude level appropriate for the device under test. The default value = -10 dBm. 0 dBm may be used for systems with higher loss.
3. Adjust the spectrum analyzer control settings (for example frequency, resolution bandwidth, sweep time and input attenuation) as appropriate for the signal separation device and device being tested.
4. Establish a 0 dB reference trace for normalizing the measured data.
 - a. Remove the device to be measured and replace it with a short or open.
 - b. Press the **View/Trace** front panel key.
 - c. Press the **More** menu key.
 - d. Press the **Normalize** menu key, **Store Ref (1 - 3)** and **normalize On**.
5. Make the measurement.
 - a. Re-connect the device to be measured to the signal separation device.
 - b. Read the measurement and save it if required.

Example

The following example measures the return loss of a bandpass filter (BPF).

1. Adjust the spectrum analyzer control settings.

With the BPF in the measurement path, adjust the spectrum analyzer control settings for the correct frequency coverage, resolution bandwidth, input attenuation and source power.

NOTE

Having adjusted the control settings, do not alter them during the course of the measurement.

To obtain a faster sweep, change the coupling from normal spectrum analyzer mode to stimulus response mode by pressing the **Sweep** front panel key and **Swp Coupling SR SA** menu key until **SR** is underlined.

2. Establish a 0 dB reference trace for normalizing the measured data.

Normalization removes any frequency-response errors introduced by the components of the test setup before making the measurement. It is performed by removing the device to be tested and measuring a short or open. As neither can dissipate the energy of the incident signal—100% reflection takes place, the wave is reflected back from the short or open—that is, 100% reflection takes place—to the spectrum analyzer where its value is displayed:

- a. Remove the BPF and connect a short in its place as shown in figure 5-5.

Figure 5-5 Calibrating the Spectrum Analyzer for Return Loss

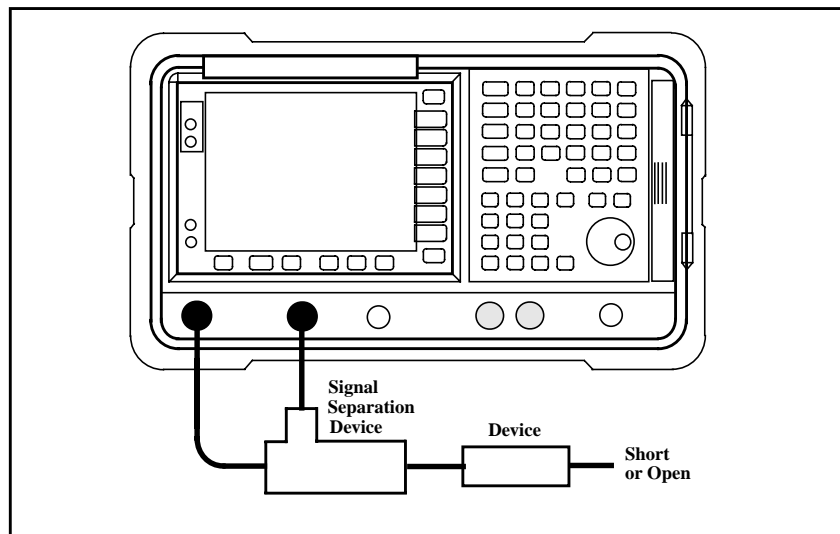

- b. Press the **View/Trace** front panel key.
- c. Press the **More** menu key.
- d. Press the **Normalize** menu key, **Store Ref (1 - 3)** and **normalize On**.

This procedure establishes a 0 dB reference trace which is stored in the ESA/spectrum analyzer. It is then used to normalize the measured data automatically by subtracting the short circuit calibration from the measurement obtained with the device.

3. Make the measurement.
 - a. Re-connect the device in place of the short/open.
 - b. Read the measurement and save it if required.
The return loss of the device is displayed on the screen. Use the marker to evaluate the result and save the trace if required.

An example is shown in Figure 5-6.

Figure 5-6 Example Return Loss Measurement for a Bandpass Filter

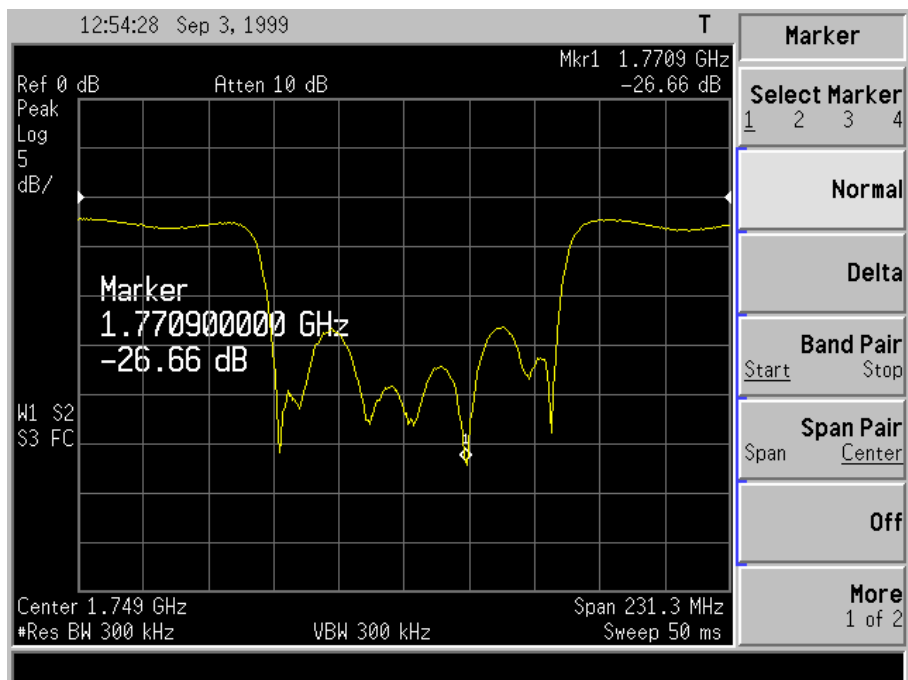

Converting Return Loss to VSWR

Return loss can be expressed as a voltage standing wave ratio (VSWR) value using the following table or formula:

Table 5-2 Power to VSWR Conversion

Return Loss (dB)	VSWR	Return Loss (dB)	VSWR	Return Loss (dB)	VSWR	Return Loss (dB)	VSWR	Return Loss (dB)	VSWR
4.0	4.42	14.0	1.50	18.0	1.29	28.0	1.08	38.0	1.03
6.0	3.01	14.2	1.48	18.5	1.27	28.5	1.08	38.5	1.02
8.0	2.32	14.4	1.47	19.0	1.25	29.0	1.07	39.0	1.02
10.0	1.92	14.6	1.46	19.5	1.24	29.5	1.07	39.5	1.02
10.5	1.85	14.8	1.44	20.0	1.22	30.0	1.07	40.0	1.02
11.0	1.78	15.0	1.43	20.5	1.21	30.5	1.06	40.5	1.02
11.2	1.76	15.2	1.42	21.0	1.20	31.0	1.06	41.0	1.02
11.4	1.74	15.4	1.41	21.5	1.18	31.5	1.05	41.5	1.02
11.6	1.71	15.6	1.40	22.0	1.17	32.0	1.05	42.0	1.02
11.8	1.69	15.8	1.39	22.5	1.16	32.5	1.05	42.5	1.02
12.0	1.67	16.0	1.38	23.0	1.15	33.0	1.05	43.0	1.01
12.2	1.65	16.2	1.37	23.5	1.14	33.5	1.04	43.5	1.01
12.4	1.63	16.4	1.36	24.0	1.13	34.0	1.04	44.0	1.01
12.6	1.61	16.6	1.35	24.5	1.13	34.5	1.04	44.5	1.01
12.8	1.59	16.8	1.34	25.0	1.12	35.0	1.04	45.0	1.01
13.0	1.58	17.0	1.33	25.5	1.11	35.5	1.03	45.5	1.01
13.2	1.56	17.2	1.32	26.0	1.11	36.0	1.03	46.0	1.01
13.4	1.54	17.4	1.31	26.5	1.10	36.5	1.03	46.5	1.01
13.6	1.53	17.6	1.30	27.0	1.09	37.0	1.03	47.0	1.01
13.8	1.51	17.8	1.30	27.5	1.09	37.5	1.03	47.5	1.01

$$\text{VSWR} = \frac{1 + 10^{\frac{-\text{RL}}{20}}}{1 - 10^{\frac{-\text{RL}}{20}}}$$

Where: RL is the measured return loss value.

VSWR is sometimes stated as a ratio. For example: 1.2:1 (“one point two to one”) VSWR. The first number is the VSWR value taken from the table or calculated using the formula. The second number is always 1.

Making Loss/Gain Measurements

Purpose

Loss/gain measurements are used to verify the performance of devices or components as illustrated by the following examples:

- A loss measurement can be used to test the performance of a base station's cables. Lower than expected base station power measurements could be caused by faulty cables. A cable's role in the problem can be determined by measuring the loss of the cable and comparing the result to the expected value.
- A gain measurement can be used to test the performance of an amplifier. A lower than expected gain measurement could indicate a fault with the amplifier.

Making the measurement

NOTE

The spectrum analyzer must be in spectrum analyzer mode for this measurement.

1. Connect the tracking generator to the device input and the device output to the input of the spectrum analyzer as shown in figure 5-7.

Figure 5-7 Loss/Gain Measurement Set-up

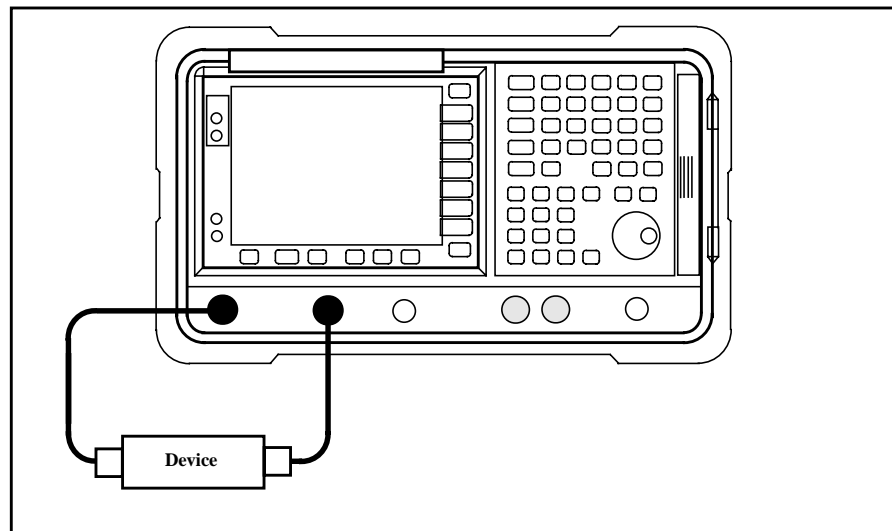

2. Turn on the tracking generator.
 - a. Press the **Source** front panel key.
 - b. Press the **Amplitude** menu key so that the tracking generator is turned on.
 - c. Set an amplitude level appropriate for the device under test.
3. Adjust the spectrum analyzer control settings (for example frequency, resolution bandwidth, sweep time and input attenuation) as appropriate for the device being tested.
4. Establish a 0 dB reference trace for normalizing the measured data.
 - a. Remove the device from the measurement path.
 - b. Press the **View/Trace** front panel key.
 - c. Press the **More** menu key.
 - d. Press the **Normalize** menu key, **Store Ref (1 - 3)** and **normalize On**.
5. Make the measurement.
 - a. Re-connect the device.
Re-connect the tracking generator RF output to the device input and the device output to the spectrum analyzer input as shown in figure 1.
 - b. Read the measurement and save it if required.

Example

The following example measures the gain/loss of a bandpass filter (BPF).

1. Adjust the spectrum analyzer control settings.

With the BPF in the measurement path, adjust the spectrum analyzer control settings for the specific type of measurement to be made. For example:

- If making a passband-ripple measurement, the spectrum analyzer requires a narrow span and typically < 10 dB per vertical division to get more resolution on the display.
- If making a stop-band attenuation measurement, the spectrum analyzer requires a wide span and a narrow RBW filter.

NOTE

Having adjusted the control settings, do not alter them during the course of the measurement.

To obtain a faster sweep, change the coupling from normal spectrum analyzer mode to stimulus response mode by pressing the **Sweep** front panel key and **Swp Coupling SR SA** menu key until **SR** is underlined. Note that the limitation on sweep speed is typically determined by the device and care must be taken to allow the device sufficient time to respond to the signal being passed through it. If the auto stimulus-response-mode sweep is too fast, slow it down until no changes in amplitude occur on the trace.

2. Establish a 0 dB reference trace for normalizing the measured data.

Normalization removes any frequency-response errors introduced by the components of the test setup before making the measurement. It is performed by removing the device and measuring a 'thru' from the source directly to the receiver. This establishes a 0 dB reference trace which is stored in the spectrum analyzer and then used to normalize the measured data:

- a. Remove the BPF and connect the tracking generator output directly to the spectrum analyzer input using the same test cables to be used when making the measurement. Use a thru adaptor to connect the test cables if necessary.
- b. Press the **View/Trace** front panel key.
- c. Press the **More** menu key.
- d. Press the **Normalize** menu key, **Store Ref (1 - 3)** and **normalize On**.

This procedure automatically subtracts the measured 'thru' level from an ideal 'thru' (a flat reference line) and stores it. This reference is then used to normalize the measured signal where:

$$\text{normalized signal} = \text{measured signal} - \text{error}$$

With the device disconnected, the displayed trace is then flat, or normalized.

The normalized trace can be moved to a different position on the display by pressing the **Norm Ref Posn** menu key. This may be useful if the device to be tested has positive gain, such as an amplifier.

3. Make the measurement.

- a. Re-connect the tracking generator to the BPF input and the BPF output to the spectrum analyzer.
- b. Read the measurement and save it if required.
Use the marker to evaluate the result and save the trace if required.

An example is shown in figure 5-8.

Figure 5-8 Example Loss/Gain Measurement for a Bandpass Filter

